



**Maryland**  
Department of  
the Environment

Wes Moore, Governor  
Aruna Miller, Lt. Governor

Serena McIlwain, Secretary  
Suzanne E. Dorsey, Deputy Secretary

October 23, 2023

SHM Oxford Boat Yard & Marina  
c/o Doldon W. Moore and Associates LLC  
Attn: Doldon Moore  
8321 Quince View Lane  
Owings, MD 20736

Via email: [dwmoorej@verizon.net](mailto:dwmoorej@verizon.net)

Re: Agency Interest Number: 175349  
Tracking Number: 202260968  
Tidal Authorization Number: 23-WQC-0025

Dear SHM Oxford Boat Yard and Marina:

Your project did not qualify for approval under the Maryland State Programmatic General Permit (MDSPGP); therefore a separate review and issuance of the federal permit will be required by the U.S. Army Corps of Engineers. The federal permit is not attached.

Additionally, your project required a Wetlands License to be approved and issued by the Maryland Board of Public Works (BPW). The Wetlands License will be sent to you by BPW's Wetlands Administrator.

A project that does not qualify for approval under the MDSPGP requires an individual Water Quality Certification (WQC) to be issued by the Maryland Department of the Environment, which is attached. Please take a moment to read and review your WQC to ensure that you understand the limits of the authorized work and all of the general and special conditions.

You should not begin any work until you have obtained all necessary State, local, and federal authorizations. Please contact Michaela Harrington at [michaela.harrington@maryland.gov](mailto:michaela.harrington@maryland.gov) or 410-537-4182 with any questions.

Sincerely,

*Tammy Roberson*

Tammy K. Roberson  
Chief  
Tidal Wetlands Division



STATE OF MARYLAND  
DEPARTMENT OF THE ENVIRONMENT  
WATER AND SCIENCE ADMINISTRATION  
WATER QUALITY CERTIFICATION



23-WQC-0025

EFFECTIVE DATE: **October 23, 2023**  
CERTIFICATION HOLDER: **SHM Oxford Boat Yard & Marina**  
**c/o Doldon Moore**  
ADDRESS: **407 Strand Rd, Parcel 655**  
**Oxford, MD 21654**  
PROJECT LOCATION: **407 Strand Rd, Parcel 655**  
**Oxford, MD 21654**

**UNDER AUTHORITY OF SECTION 401 OF THE FEDERAL WATER POLLUTION CONTROL ACT AND ITS AMENDMENTS AND IN ACCORDANCE WITH § 9-313 THROUGH § 9-323, INCLUSIVE, OF THE ENVIRONMENT ARTICLE, ANNOTATED CODE OF MARYLAND, THE MARYLAND DEPARTMENT OF THE ENVIRONMENT, WATER AND SCIENCE ADMINISTRATION HAS DETERMINED THAT THE REGULATED ACTIVITIES DESCRIBED IN THE REQUEST FOR CERTIFICATION FOR THE PROPOSED SHM OXFORD BOAT YARD AND MARINA DREDGING AND MARINA RECONFIGURATION PROJECT AND AS DESCRIBED IN THE ATTACHED PLAN SHEETS DATED JUNE 23, 2023 AND ANY SUBSEQUENT MODIFICATIONS APPROVED BY THE DEPARTMENT WILL NOT VIOLATE MARYLAND'S WATER QUALITY STANDARDS, IF CONDUCTED IN ACCORDANCE WITH THE CONDITIONS OF THIS CERTIFICATION.**

THIS CERTIFICATION DOES NOT RELIEVE THE APPLICANT OF RESPONSIBILITY FOR OBTAINING ANY OTHER APPROVALS, LICENSES, OR PERMITS IN ACCORDANCE WITH FEDERAL, STATE, OR LOCAL REQUIREMENTS AND DOES NOT AUTHORIZE COMMENCEMENT OF THE PROPOSED PROJECT. A COPY OF THIS REQUIRED CERTIFICATION HAS BEEN SENT TO THE CORPS OF ENGINEERS. THE CERTIFICATION HOLDER SHALL COMPLY WITH THE CONDITIONS LISTED BELOW.

## **PROJECT DESCRIPTION**

Install a 393-foot long by 8-foot wide floating pier, a 30-foot long by 5-foot wide A.D.A. gangway, a 92-foot long by 8-foot wide "T"-shaped floating platform, five 50-foot long by 5-foot wide floating finger piers, one 45-foot long by 5-foot floating finger pier, four 40-foot long by 5-foot wide floating finger piers, four 30-foot long by 3-foot wide floating finger piers, one 40-foot long by 3-foot wide finger pier, all extending a maximum of 340-feet channelward of the mean high water line. Install two fixed travel lift piers that are 62-foot long by 6-foot wide with two adjacent 62-foot long by 3-foot wide walkways, all extending a maximum of 62 feet channelward of the mean high water line. Install a 320-foot long by 8-foot wide floating pier, a 60-foot long by 8-foot wide "L"-shaped floating pier, five 60-foot long by 5-foot wide floating finger piers, two 30-foot long by 3-foot wide floating finger piers, a 15-foot long by 6-foot wide access ramp, a 30-foot long by 5-foot wide A.D.A. gangway, a 125-foot long by 4-foot wide floating access pier, a 30-foot long by 5-foot wide floating finger pier, a 33-foot long by 5-foot wide floating finger pier, all extending a maximum of 332 feet channelward of the mean high water line. Construct and backfill 522 linear feet of replacement vinyl bulkhead within a maximum 1.5 feet channelward of a deteriorated bulkhead. Maintenance dredge two areas totaling .66 acres to the depth of 8 feet below mean low water and deposit approximately 3,800 cubic yards

of dredge material to an approved upland disposal site located at R.D. Baker & Sons, Inc, 501 4-H Park Rd, Queenstown, MD, 21658; and to provide for periodic maintenance dredging for six years.

## **GENERAL CONDITIONS**

1. All water quality-related performance standards and conditions required by the Department in any state issued authorization for activities in tidal wetlands, nontidal wetlands, their 100-year floodplains, nontidal wetlands buffers, or nontidal wetland expanded buffers to ensure that any discharges will not result in a failure to comply with water quality standards in COMAR 26.08.02 or any other water quality requirements of state law or regulation shall be met.
2. This Certification does not obviate the need to obtain required authorizations or approvals from other State, federal or local agencies as required by law.
3. All additional authorizations or approvals, including self-certifying General Permits issued by the Department, shall be obtained and all conditions shall be completed in compliance with such authorizations.
4. The proposed project shall be constructed in accordance with the approved final plan by the Department, or, if Department approval is not required, the plan approved by the U.S. Army Corps of Engineers, and its approved revisions.
5. All fill and construction materials not used in the project shall be removed and disposed of in a manner which will prevent their entry into waters of this State.
6. This Certification does not authorize any injury to private property, any invasion of rights, or any infringement of federal, state, or local laws or regulations.
7. Authorized representatives of the Department shall be provided access to the site of authorized activities during normal business hours to conduct inspections and evaluations of the operations and records necessary to assure compliance with this Certification.
8. No stockpiles of any material shall be placed in Waters of the U.S. or state or private tidal wetlands.
9. Temporary construction trailers or structures, staging areas and stockpiles shall not be located within tidal wetlands, nontidal wetlands, nontidal wetlands buffers, or the 100-year floodplain unless specifically included on the Approved Plan.
10. This Certification is valid for the project identified herein and the associated U.S. Army Corps of Engineers authorization NAB-2022-60968 until such time that it expires or is not administratively extended.

## **SPECIAL CONDITIONS**

1. All Critical Area requirements shall be followed and all necessary authorizations from the Critical Area Commission (“Commission”) shall be obtained. This Certificate does not constitute authorization for disturbance in the 100-foot Critical Area Buffer. “Disturbance” in the Buffer means clearing, grading, construction activities, or removal of any size of tree or vegetation. Any anticipated Buffer disturbance requires prior written approval, before commencement of land disturbing activity, from local jurisdiction in the form of a Buffer Management Plan.
2. All work performed under this Water Quality Certificate shall be conducted by a marine contractor licensed by the Marine Contractors Licensing Board (MCLB) in accordance with Title 17 of the Environment Article of Annotated Code of Maryland. Licensing by MCLB shall occur prior to the beginning of construction activities. A list of licensed marine contractors may be obtained by contacting the MCLB at 410-537- 3249, by e-mail at MDE.MCLB@maryland.gov or by accessing the Maryland Department of the Environment, Environmental Boards webpage.
3. The issuance of this Certificate is not a validation or authorization by the Department for any of the existing structures depicted on the plan sheets on the subject property that is not part of the authorized work description, nor does it relieve the Certificate Holder of the obligation to resolve any existing noncompliant structures and activities within tidal wetlands.
4. The Certificate Holder shall transport all dredged material in watertight trucks. No dredged material shall be discharged onto the roadways of the State.
5. The Certificate Holder shall dispose of dredged material only at the dredge disposal site approved by this Water Quality Certification. The Certificate Holder shall submit an application for modification of the Certificate to MDE for approval of any dredge disposal site not authorized within the Certificate.
6. The Certificate Holder shall conduct subsequent maintenance dredging within the scope of this license in terms of authorized dredge area and authorized depths. The Certificate Holder shall:
  1. Dredge no more than 500 cubic yards of material at each maintenance dredging.
  2. Comply with all applicable conditions of this license.
  3. Submit a detailed dredged material disposal plan to be approved by the Water and Science Administration, Tidal Wetlands Division prior to the start of dredging.
  4. Notify and receive approval from the Water and Science Administration, Compliance Program a minimum of 10 days prior to the start of each maintenance dredging operation.
  5. The Certificate Holder shall stake the dredge area and receive approval from the Water and Science Administration’s, Compliance Division prior to the start of dredging.
7. The Certificate Holder shall conduct a post dredge bathymetric survey and forward to the Water and Science Administration, Tidal Wetlands Division within 45 days after the termination of any phase of dredging.
8. The Certificate Holder shall conduct maintenance dredging within the scope of this Certification in terms of authorized dredged area, volume of material and authorized depths.
9. The Certificate Holder shall deploy and maintain a turbidity curtain tightly around and channelward of the project area prior to any dredging within the entrance channel and basin during oyster

spawning from June 1st and September 30th, oyster winter quiescence from December 15th and March 15th.

## **CITATIONS AND STATEMENTS OF NECESSITY**

1. Statement of Necessity for General Conditions 1, 2, 3, 4, and Special Conditions 1, 3: These conditions are necessary to ensure that water quality standards are met, and designated uses are maintained.

Citations: Federal and state laws which authorize this condition include but are not limited to: 33 U.S.C. § 1341(a), (b), & (d); 33 U.S.C. § 1251(b); 33 U.S.C. § 1370; Md. Ann. Code, Env. Article, Title 1, Subtitles 3 and 4; Md. Ann. Code, Env. Article, Title 5, Subtitles 5 and 9; Md. Ann. Code, Env. Article, Title 9, Subtitle 3; Md. Ann. Code, Env. Article, Title 16; COMAR 26.08; COMAR 26.08.02.10G(3); COMAR 26.23.02.06; COMAR 26.17.01; COMAR 26.23; COMAR 26.24

2. Statement of Necessity for General Conditions 5, 8, 9: Fill or construction material within or adjacent to regulated resources may cause discharges resulting in turbidity in excess of water quality standards and interfere with designated uses of growth and propagation of fish, other aquatic life, wildlife; and other designated uses; and fail to meet general water quality criteria that waters not be polluted by substances in amounts sufficient to be unsightly or create a nuisance.

Citation: 26.08.02.03B(1)-B(2); COMAR 26.23; COMAR 26.24; COMAR 26.17.04

3. Statement of Necessity for General Condition 6: This condition is necessary to clarify the scope of this certification to ensure compliance with water quality regulations, without limiting restrictions through other requirements.

Citation: Federal and state laws which authorize this condition include but are not limited to: 33 U.S.C. § 1341(a), (b), & (d); 33 U.S.C. § 1251(b); 33 U.S.C. § 1370; Md. Ann. Code, Env. Article, Title 1, Subtitles 3 and 4; Md. Ann. Code, Env. Article, Title 5, Subtitles 5 and 9; Md. Ann. Code, Env. Article, Title 9, Subtitle 3; Md. Ann. Code, Env. Article, Title 16; COMAR 26.08, COMAR 26.08.02.10E; COMAR 26.23.02.06; COMAR 26.17.04; COMAR 26.23; COMAR 26.24

4. Statement of Necessity for General Condition 7: Conditions of certification involve precise actions to comply with water quality standards. Site inspection may be necessary to ensure that limits, methods, and other requirements are met to ensure that water quality standards are met and designated uses are maintained. These conditions are necessary to ensure that the activity was conducted, and project completed according to terms of the authorization/certification, while allowing for review of in-field modifications which may have resulted in discharges to ensure that water quality standards were met. Designated uses include support of estuarine and marine aquatic life and shellfish harvesting and for growth and propagation of fish, other aquatic life, and wildlife

Citation: Federal and state laws that authorize this condition include but are not limited to: 33 U.S.C. § 1341(a), (b), & (d); 33 U.S.C. § 1251(b); 33 U.S.C. § 1370; Md. Ann. Code, Env. Article, Title 1, Subtitles 3 and 4; Md. Ann. Code, Env. Article, Title 5, Subtitles 5 and 9; Md. Ann. Code, Env. Article, Title 9, Subtitle 3; Md. Ann. Code, Env. Article, Title 16; COMAR 26.08; COMAR 26.08.02.03B(1)(b); COMAR 26.08.02.03B(2); COMAR 26.23.02.06; COMAR 26.23; COMAR 26.24; COMAR 26.17.04

5. Statement of Necessity for General Condition 9: This condition is necessary to qualify the period of applicability of the terms and conditions of this Certification to be protective of Maryland water quality standards.

Citations: Federal and state laws which authorize this condition include but are not limited to: 33 U.S.C. § 1341(a), (b), & (d); 33 U.S.C. § 1251(b); 33 U.S.C. § 1370; 40 C.F.R. 121, 15 C.F.R. 930, Md. Ann. Code, Env. Article, Title 1, Subtitles 3 and 4; Md. Ann. Code, Env. Article, Title 5, Subtitles 5 and 9; Md. Ann. Code, Env. Article, Title 9, Subtitle 3; Md. Ann. Code, Env. Article, Title 16; COMAR 26.08; COMAR 26.17.04; COMAR 26.23; COMAR 26.24

6. Statement of Necessity for Special Condition 2: Expertise for conducting certain activities is required to ensure that there is no violation of water quality standards nor interference with designated uses. This condition is necessary to ensure that discharges will be conducted in a manner which does not violate water quality criteria nor interfere with designated uses.

Citation: COMAR 26.08.02.02B(2)- B(4); COMAR 26.08 02.03B(2)(d) – (e ); COMAR 26.08.02.03B(1)(b); 26.08.02.03B(2); COMAR 23.02.04.04

7. Statement of Necessity for Special Conditions 4, 5, 6, 9: Unauthorized discharges may enter regulated waters as result of activity or structural failure. A plan to address inadvertent discharges will prevent or address further violations of water quality standards and failure of water to meet designated uses, including uses of growth and propagation of fish, other aquatic life, wildlife; and other designated uses; and fail to meet general water quality criteria that waters not be polluted by substances in amounts sufficient to be unsightly or create a nuisance.

Citation COMAR 26.08.02.02B(1)d; COMAR 26.08.02.02B(3); COMAR 26.08.02.03B(1) and B(2); 26.08.02.01B(2); 26.08.02.02B(1)

8. Statement of Necessity for Special Condition 7: The condition is necessary to ensure that the dredging results in water depths which are appropriate to support designated uses of fishing and water contact recreation and propagation of fish, other aquatic life and wildlife; and ensure that no discharges are unsightly, create a nuisance, change to an objectionable color or interferes with designated uses.

Citations: COMAR 26.08.02.01B(2); COMAR 26.08.02.02B(1); 26.08.02.02B(3); COMAR 26.08.02.03B

9. Statement of Necessity for Special Condition 8: The limits on the scope of maintenance dredging are necessary to ensure that no discharges would violate water quality standards and designated uses for water clarify, turbidity, growth and propagation of fish, other aquatic life, and wildlife; and water contact recreation

Citations: COMAR 26.08.02.02B(1)(d); COMAR 26.08.02.02B(3); COMAR 26.08.02.03B

10. Statement of Necessity for Special Condition 9: The discharge and deposition of material within or adjacent to regulated resources may result in discharges that result in impacts to water quality and designated uses.

Citations: COMAR 26.08.02.02.B.(3); COMAR 26.08.02.03-3.C.(2)d.(5)

**CERTIFICATION APPROVED**

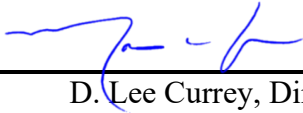

---

D. Lee Currey, Director  
Water and Science Administration

10/24/2023

---

Date

Tracking Number: 202260968  
Agency Interest Number: 175346

Effective Date: October 23, 2023

Enclosure: Plan Sheets dated June 23, 2023

cc: WSA Inspection & Compliance Program  
Army Corps of Engineers

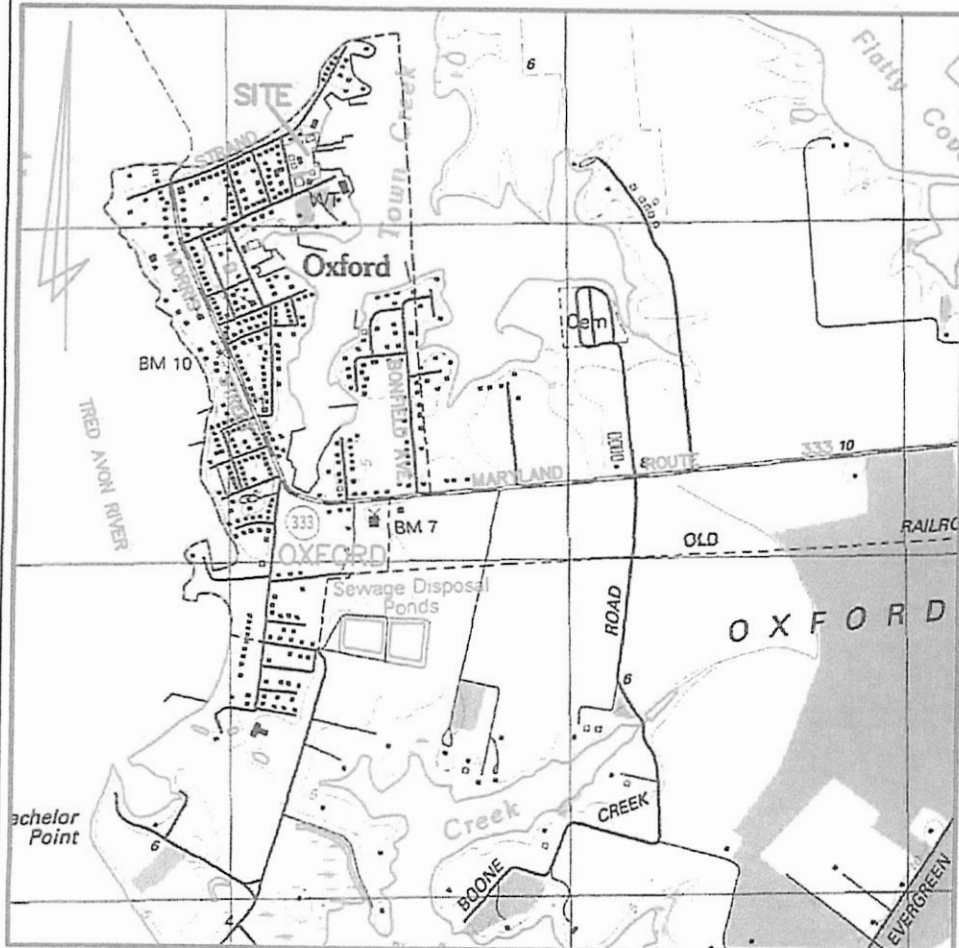

VICINITY MAP

NOT TO SCALE

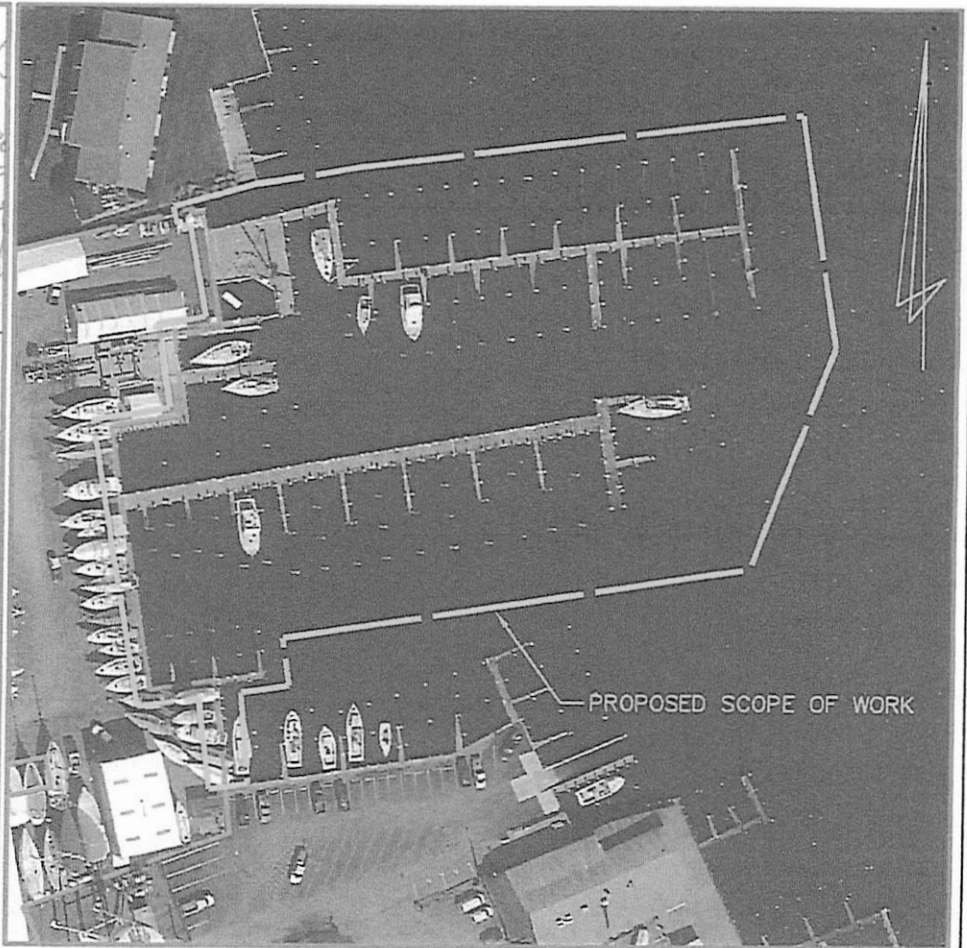

LOCATION MAP

NOT TO SCALE

22-WL-0617  
 202260968  
 175349  
 06/23/2023  
 MTH  
 Sheet 1 of 11

PERMIT  
 PIER REPLACEMENT, BULKHEAD  
 REPLACEMENT AND DREDGING  
 FOR  
 OXFORD BOAT YARD AND MARINA  
 IN THE TOWN OF OXFORD  
 THIRD ELECTION DISTRICT, TALBOT COUNTY, MARYLAND  
 PREPARED FOR : SAFE HARBOR MARINAS  
 DATE : MAY 16, 2022

SHEET T-1

**D**AVIS, **M**OOORE, **S**HEARON  
 & ASSOCIATES, LLC

ENGINEERING, DRAFTING/DESIGN,  
 ENVIRONMENTAL SERVICES & SURVEYING

P.O. BOX 80  
 CENTREVILLE, MARYLAND 21617  
 PHONE : 1-443-252-9130  
 FAX : 1-443-252-9148



TRED AVON  
CONDOMINIUMS

LIMITS OF BULKHEAD  
REPLACEMENT

EXISTING PILINGS & FIXED  
PIER TO BE REMOVED  
TYPICAL

RIPARIAN LINE

EXISTING DECK AND  
PILINGS TO BE REMOVED

FIXED DOCK

EXISTING TRAVEL LIFT  
PIERS TO BE REMOVED

22-WL-0617  
202260968  
175349  
06/23/2023  
MTH  
Sheet 2 of 11

EXISTING PILINGS & FIXED  
PIER TO BE REMOVED  
TYPICAL

LIMITS OF BULKHEAD  
REPLACEMENT

COMMISSIONERS OF OXFORD  
PERMIT

EXISTING CONDITIONS AND DEMOLITION PLAN  
FOR

OXFORD BOAT YARD AND MARINA  
IN THE TOWN OF OXFORD  
THIRD ELECTION DISTRICT, TALBOT COUNTY, MARYLAND  
PREPARED FOR : SAFE HARBOR MARINAS  
DATE : MAY 16, 2022

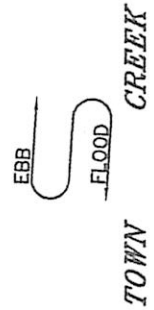

SHEET C-1

**D**AVIS, **M**OOORE, **S**HEARON  
& **A**SSOCIATES, **L**LC

ENGINEERING, DRAFTING/DESIGN,  
ENVIRONMENTAL SERVICES & SURVEYING

P.O. BOX 80  
CENTREVILLE, MARYLAND 21617  
PHONE : 1-443-262-9130  
FAX : 1-443-262-9148

TRED AVON  
CONDOMINIUMS

5'x30' ADA GATEWAY  
SEE SHEET C-3B

RIPARIAN LINE

76.0'  
LINE



PROPOSED TRAVEL LIFT PIER  
AND WALKWAY. SEE SECTION  
"A-A" ON SHEET C-3D.

6'x15' RAMP

5'x30' ADA GATEWAY  
SEE SHEET C-3B

PROPOSED 24' WIDE  
TRAVEL LIFT WELL

PROPOSED 4' WIDE  
FLOATING PIER (125')

PROPOSED 5' WIDE  
FLOATING PIERS

HARBOR

HARBOR  
LINE

EBB  
FLOOD  
TOWN  
CREEK

COMMISSIONERS OF OXFORD

PERMIT

PROPOSED MARINA PLAN

FOR

OXFORD BOAT YARD AND MARINA

IN THE TOWN OF OXFORD

THIRD ELECTION DISTRICT, TALBOT COUNTY, MARYLAND

PREPARED FOR : SAFE HARBOR MARINAS

DATE : MAY 16, 2022

22-WL-0617  
202260968  
175349  
06/23/2023  
MTH  
Sheet 3 of 11

SHEET C-2

**D**AVIS, **M**OOORE, **S**HEARON  
& ASSOCIATES, LLC

ENGINEERING, DRAFTING/DESIGN,  
ENVIRONMENTAL SERVICES & SURVEYING

P.O. BOX 80  
CENTREVILLE, MARYLAND 21617  
PHONE : 1-443-262-9130  
FAX : 1-443-292-9148

NOT TO SCALE

22-WL-0617  
 202260968  
 175349  
 06/23/2023  
 MTH  
 Sheet 4 of 11

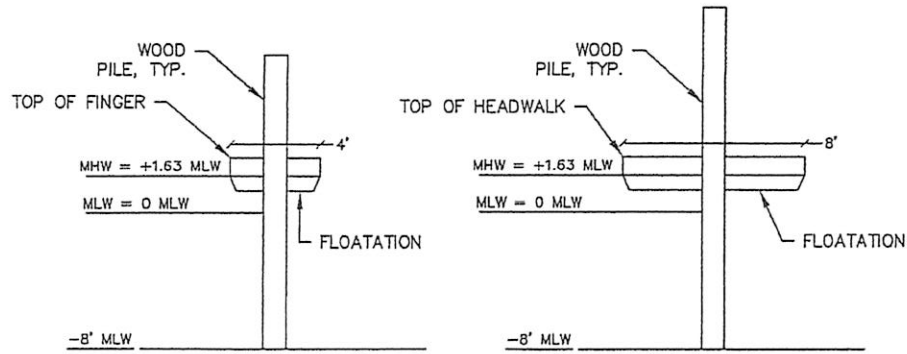

2 TYP. FLOATING DOCK

3 TYP. FLOATING HEAD DOCK

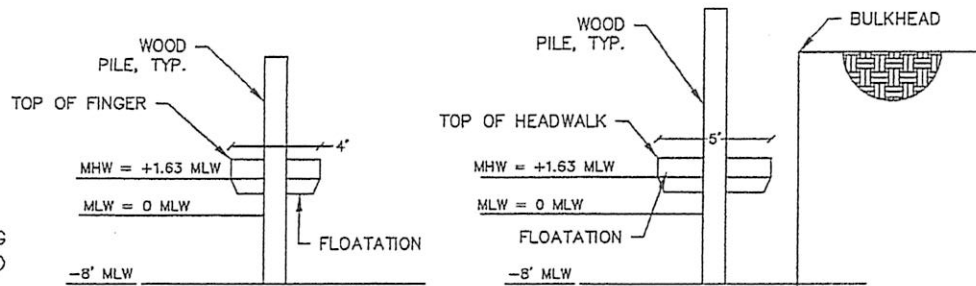

5 TYP. FLOATING DOCK SMALL BOAT BASIN

6 TYP. FLOATING HEAD DOCK SMALL BOAT BASIN

NOTE: RELATED TO DETAILS  
 DETAILS SHOWN HERON ARE FOR PERMITTING  
 PURPOSES ONLY. SEE PLANS FOR PROPOSED  
 PIER LENGTHS AND WIDTHS.

ELEVATION REFERENCE:  
 MLW = 0 MLW  
 MHW = +1.63' MLW

PERMIT  
 PROPOSED DOCK SECTIONS  
 FOR  
 OXFORD BOAT YARD AND MARINA  
 IN THE TOWN OF OXFORD  
 THIRD ELECTION DISTRICT, TALBOT COUNTY, MARYLAND  
 PREPARED FOR : SAFE HARBOR MARINAS  
 DATE : MAY 16, 2022

SHEET C-3A

**DAVIS, MOORE, SHEARON  
 & ASSOCIATES, LLC**

ENGINEERING, DRAFTING/DESIGN,  
 ENVIRONMENTAL SERVICES & SURVEYING  
 P.O. BOX 80  
 CENTREVILLE, MARYLAND 21617  
 PHONE : 1-443-262-9130  
 FAX : 1-443-262-9148

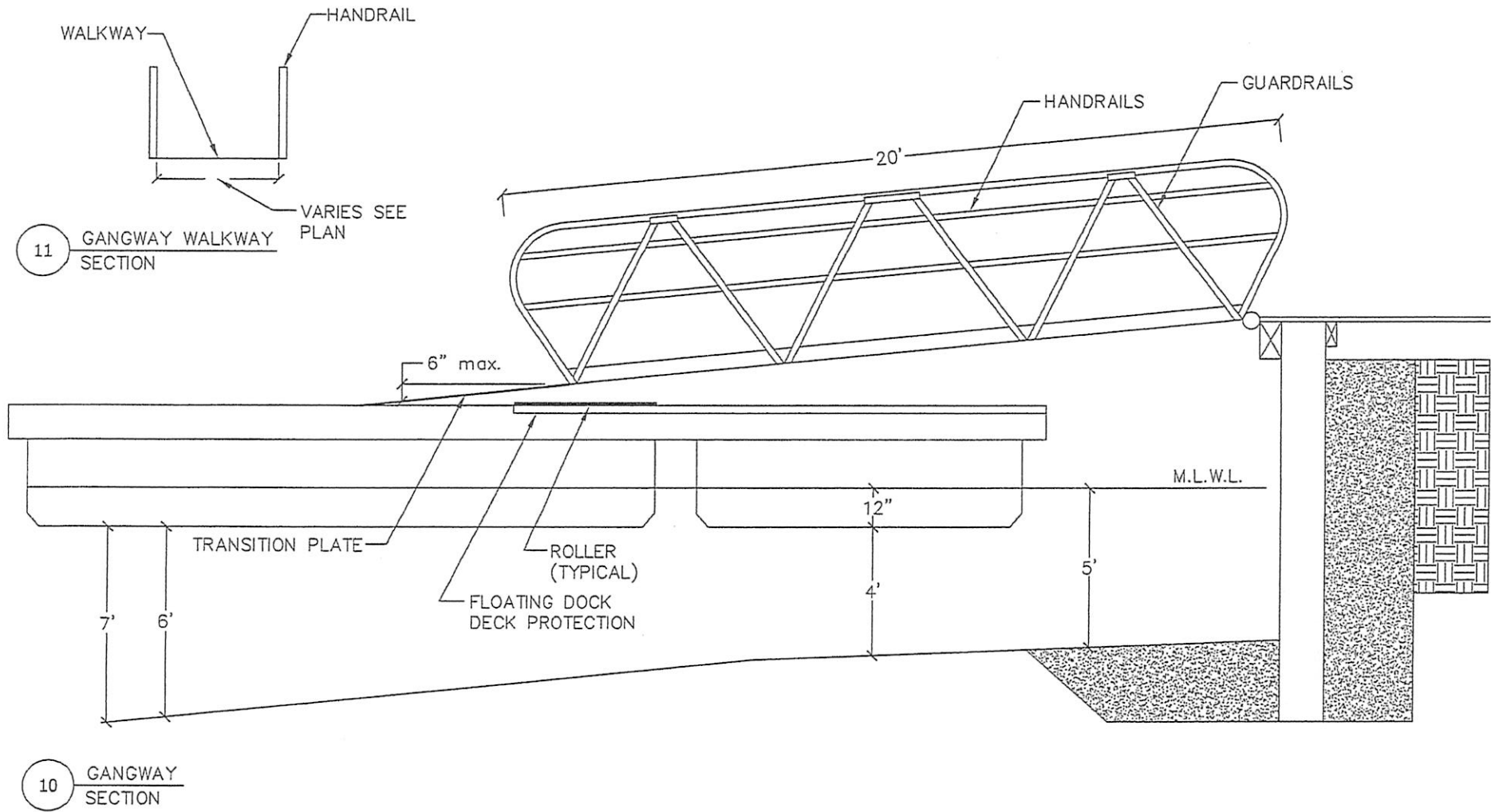

22-WL-0617  
 202260968  
 175349  
 06/23/2023  
 MTH  
 Sheet 5 of 11

PERMIT  
 PROPOSED GANGWAY SECTIONS  
 FOR  
 OXFORD BOAT YARD AND MARINA  
 IN THE TOWN OF OXFORD  
 THIRD ELECTION DISTRICT, TALBOT COUNTY, MARYLAND  
 PREPARED FOR : SAFE HARBOR MARINAS  
 DATE : MAY 16, 2022

SHEET C-3B

**DAVIS, MOORE, SHEARON & ASSOCIATES, LLC**  
 ENGINEERING, DRAFTING/DESIGN,  
 ENVIRONMENTAL SERVICES & SURVEYING  
 P.O. BOX 80  
 CENTREVILLE, MARYLAND 21617  
 PHONE : 1-443-262-9130  
 FAX : 1-443-262-9148

22-WL-0617  
 202260968  
 175349  
 06/23/2023  
 MTH  
 Sheet 6 of 11

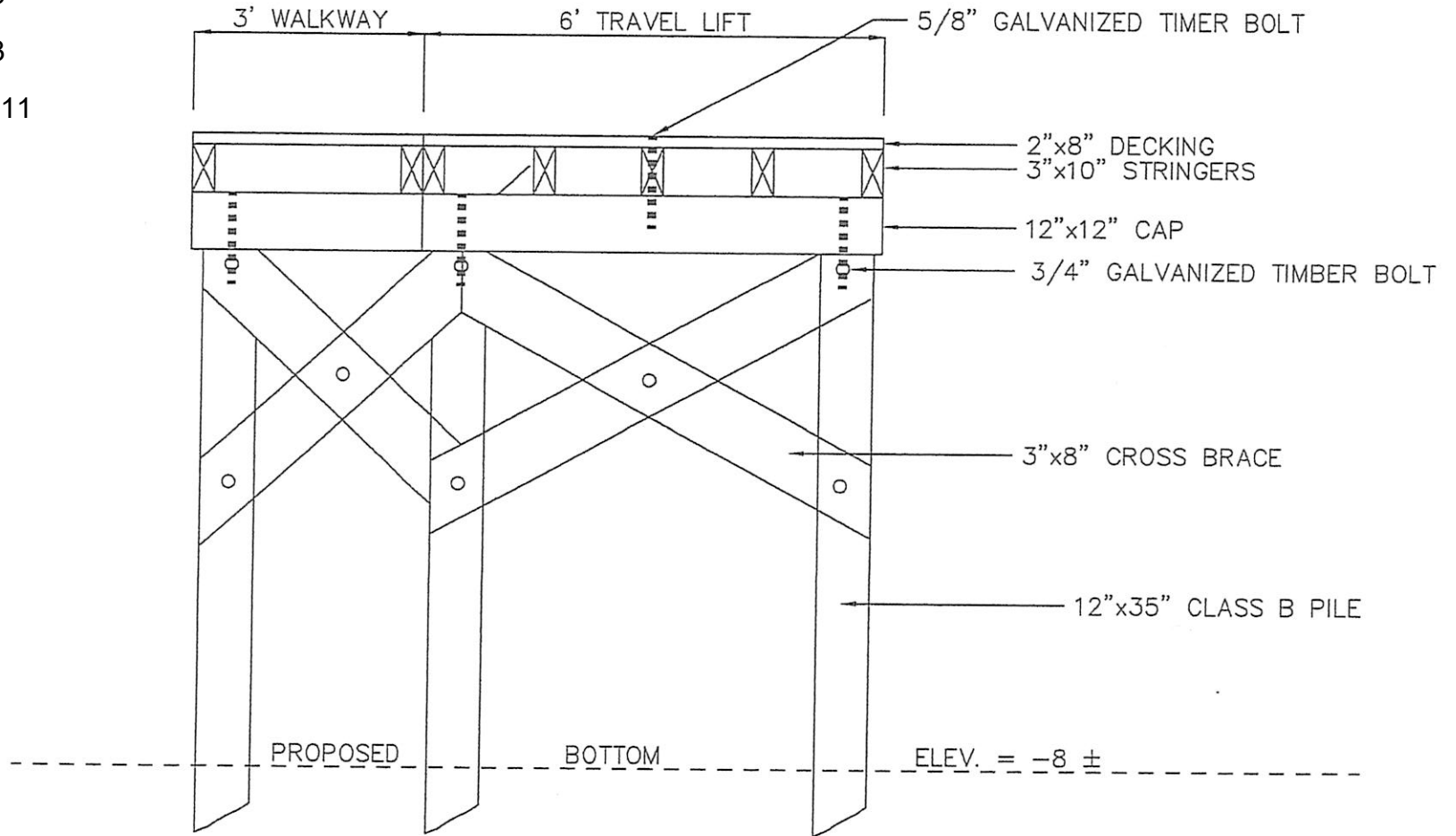

SECTION "A-A"  
 NOT TO SCALE

PERMIT  
 PROPOSED TRAVEL LIFT SECTION  
 FOR  
 OXFORD BOAT YARD AND MARINA  
 IN THE TOWN OF OXFORD  
 THIRD ELECTION DISTRICT, TALBOT COUNTY, MARYLAND  
 PREPARED FOR : SAFE HARBOR MARINAS  
 DATE : MAY 16, 2022

SHEET C-3C

**D**AVIS, **M**OORE, **S**HEARON  
 & ASSOCIATES, LLC

ENGINEERING, DRAFTING/DESIGN,  
 ENVIRONMENTAL SERVICES & SURVEYING  
 P.O. BOX 80  
 CENTREVILLE, MARYLAND 21617  
 PHONE : 1-443-262-9130  
 FAX : 1-443-262-9148

TRED AVON  
CONDOMINIUMS

BEGIN NEW  
BULKHEAD

RIPARIAN LINE

NOTE: EXISTING WOOD BULKHEAD  
TO BE REPLACED WITH VINYL SHEET  
PILE. TOTAL LENGTH = 522'

SEE  
1/C-5

EXISTING WOOD BULKHEAD  
TO BE REPLACED WITH VINYL SHEET  
PILE. NEW SHEET PILE TO BE  
INSTALLED IN SAME FOOTPRINT

22-WL-0617  
202260968  
175349  
06/23/2023  
MTH  
Sheet 7 of 11

SEE  
1/C-5

EXISTING WOOD BULKHEAD  
TO BE REPLACED WITH VINYL SHEET  
PILE. NEW SHEET PILE TO BE  
INSTALLED IN SAME FOOTPRINT

BEGIN NEW  
BULKHEAD

COMMISSIONERS OF OXFORD  
PERMIT  
PROPOSED BULKHEAD PLAN

FOR  
OXFORD BOAT YARD AND MARINA  
IN THE TOWN OF OXFORD  
THIRD ELECTION DISTRICT, TALBOT COUNTY, MARYLAND  
PREPARED FOR : SAFE HARBOR MARINAS  
DATE : MAY 16, 2022

HARBOR

HARBOR

LINE

LINE

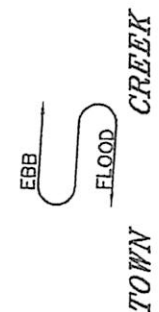

SHEET C-4

**D**AVIS, **M**OORE, **S**HEARON  
& **A**SSOCIATES, **L**LC

ENGINEERING, DRAFTING/DESIGN,  
ENVIRONMENTAL SERVICES & SURVEYING

P.O. BOX 80  
CENTREVILLE, MARYLAND 21617  
PHONE : 1-443-262-9130  
FAX : 1-443-262-9148

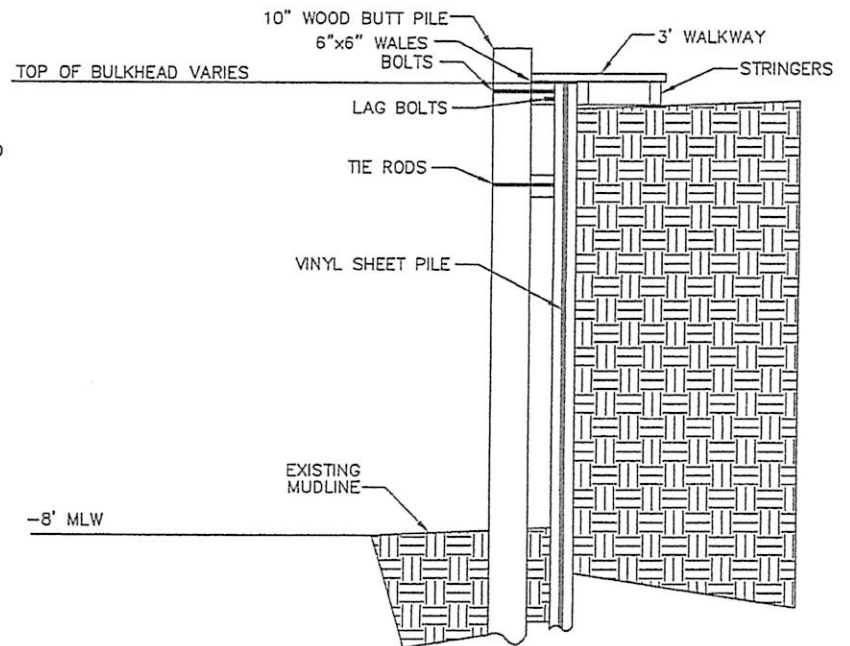
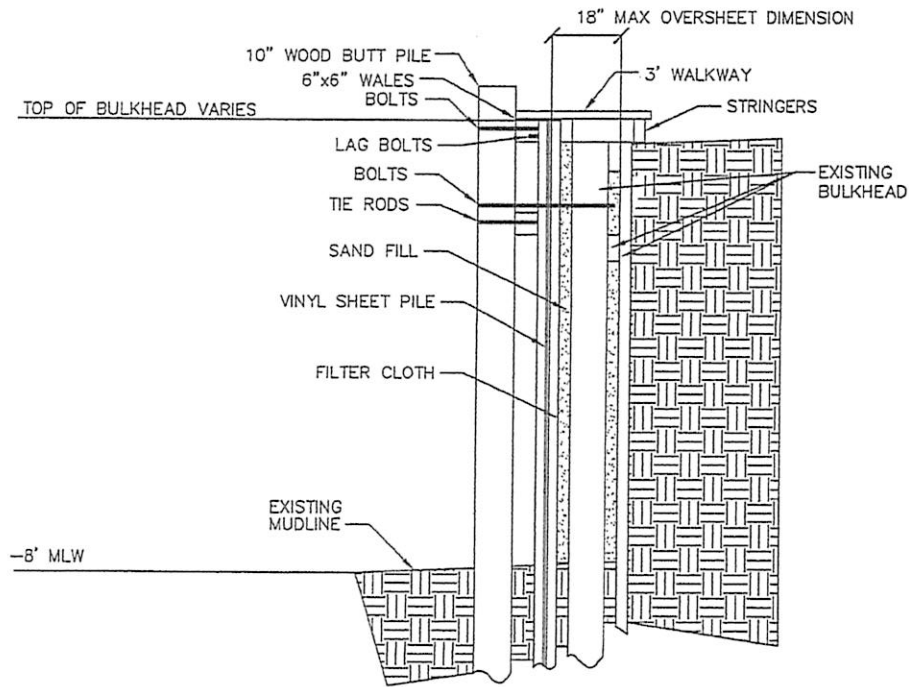

1 BULKHEAD DETAIL  
OVER SHEETING EXISTING BULKHEAD

2 BULKHEAD DETAIL  
REMOVAL OF EXISTING BULKHEAD

22-WL-0617  
202260968  
175349  
06/23/2023  
MTH  
Sheet 8 of 11

PERMIT  
PROPOSED BULKHEAD SECTIONS  
FOR  
OXFORD BOAT YARD AND MARINA  
IN THE TOWN OF OXFORD  
THIRD ELECTION DISTRICT, TALBOT COUNTY, MARYLAND  
PREPARED FOR : SAFE HARBOR MARINAS  
DATE : MAY 16, 2022

SHEET C-5

**D**AVIS, **M**OORE, **S**HEARON  
& **A**SSOCIATES, **L**LC

ENGINEERING, DRAFTING/DESIGN,  
ENVIRONMENTAL SERVICES & SURVEYING  
P.O. BOX 80  
CENTREVILLE, MARYLAND 21617  
PHONE : 1-443-262-9130  
FAX : 1-443-262-9148

TRED AVON  
CONDOMINIUMS

RIPARIAN LINE

LINE

SEE TYPICAL SECTION  
ON C-7

DREDGE TO -8.0 M.L.W.  
SEE TYPICAL SECTION  
ON C-7

22-WL-0617  
202260968  
175349  
06/23/2023  
MTH  
Sheet 9 of 11

DREDGE TO -8.0 M.L.W.  
SEE TYPICAL SECTION  
ON C-7

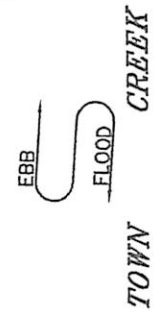

HARBOR  
LINE

COMMISSIONERS OF OXFORD

PERMIT

PROPOSED DREDGING PLAN

FOR

OXFORD BOAT YARD AND MARINA

IN THE TOWN OF OXFORD

THIRD ELECTION DISTRICT, TALBOT COUNTY, MARYLAND

PREPARED FOR : SAFE HARBOR MARINAS

DATE : MAY 16, 2022

AREA TO BE DREDGED: 0.66 ACRES  
TOTAL DREDGE VOLUME 3,800 cu yds.  
TO DESIGN DEPTH:

SHEET C-6

**D**AVIS, **M**OOORE, **S**HEARON  
& ASSOCIATES, LLC

ENGINEERING, DRAFTING/DESIGN,  
ENVIRONMENTAL SERVICES & SURVEYING

P.O. BOX 80  
CENTREVILLE, MARYLAND 21617  
PHONE : 1-443-262-9130  
FAX : 1-443-262-9148



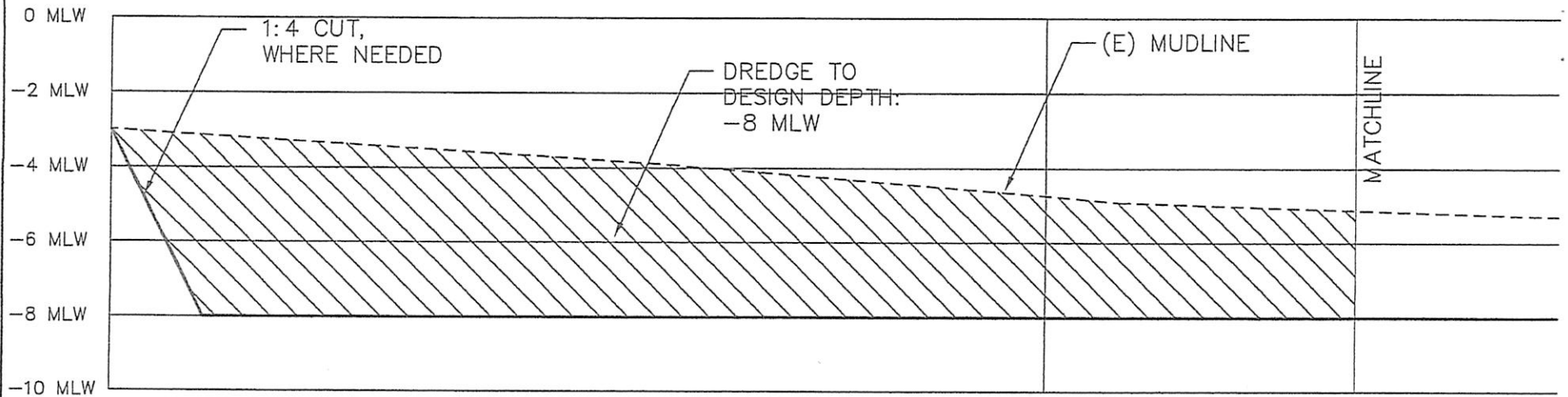

STA 0+00

STA 0+50

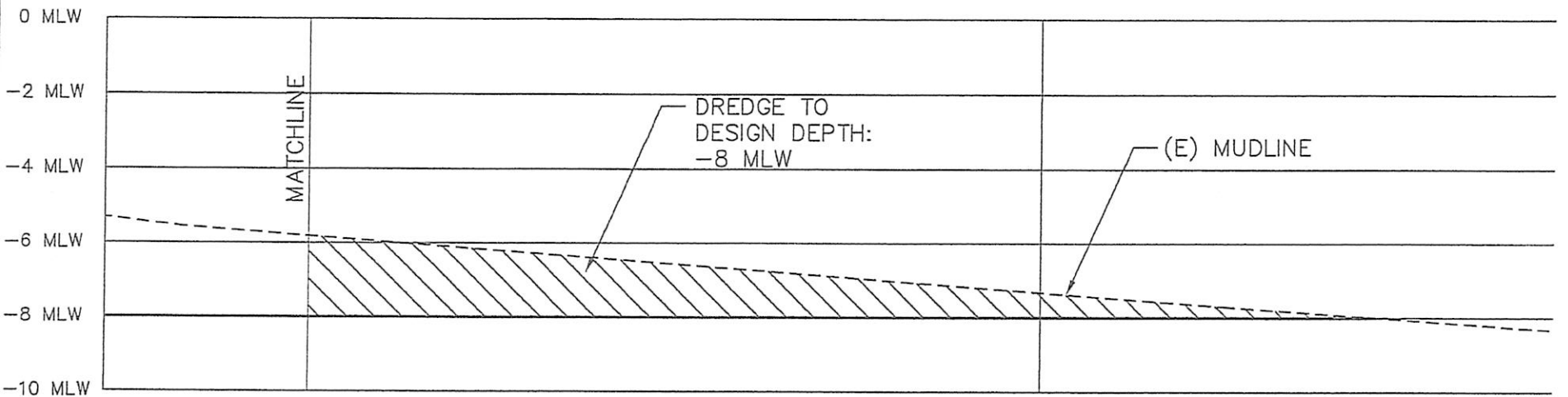

STA 0+50

STA 1+00

22-WL-0617  
 202260968  
 175349  
 06/23/2023  
 MTH  
 Sheet 10 of 11

PERMIT  
 PROPOSED DREDGING CROSS SECTION  
 FOR  
 OXFORD BOAT YARD AND MARINA  
 IN THE TOWN OF OXFORD  
 THIRD ELECTION DISTRICT, TALBOT COUNTY, MARYLAND  
 PREPARED FOR : SAFE HARBOR MARINAS  
 DATE : MAY 16, 2022

SHEET C-7

**DAVIS, MOORE, SHEARON & ASSOCIATES, LLC**  
 ENGINEERING, DRAFTING/DESIGN,  
 ENVIRONMENTAL SERVICES & SURVEYING  
 P.O. BOX 80  
 CENTREVILLE, MARYLAND 21617  
 PHONE : 1-443-262-9130  
 FAX : 1-443-262-9148

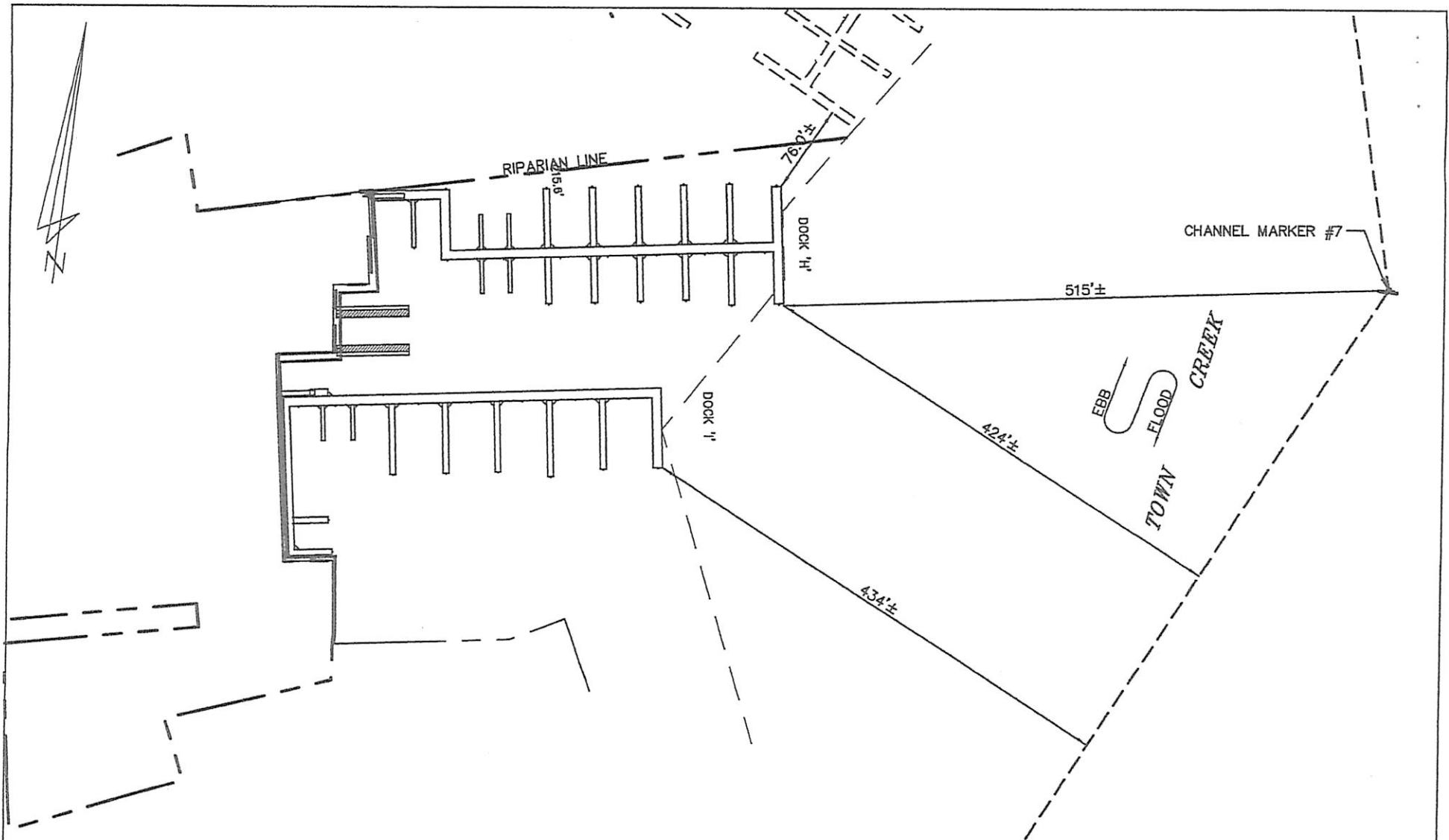

22-WL-0617  
 202260968  
 175349  
 06/23/2023  
 MTH  
 Sheet 11 of 11

PERMIT  
 CHANNEL LOCATION FOR TOWN CREEK  
 FOR  
 OXFORD BOAT YARD AND MARINA  
 IN THE TOWN OF OXFORD  
 THIRD ELECTION DISTRICT, TALBOT COUNTY, MARYLAND  
 PREPARED FOR : SAFE HARBOR MARINAS  
 DATE : MAY 16, 2022

CHANNEL MARKER #8

SHEET C-8

**DAVIS, MOORE, SHEARON  
 & ASSOCIATES, LLC**

ENGINEERING, DRAFTING/DESIGN,  
 ENVIRONMENTAL SERVICES & SURVEYING

P.O. BOX 80  
 CENTREVILLE, MARYLAND 21617  
 PHONE : 1-443-262-9130  
 FAX : 1-443-262-9148