

January 6, 2026

Ms. Suna Yi Sariscak
Air Quality Permits Program
Air & Radiation Management Administration
Maryland Department of the Environment
1800 Washington Boulevard, Suite 720
Baltimore, Maryland 21230-1720

Subject: Application for Permit to Construct
Perry Point VA Medical Center, Perry Point, MD

Dear Ms. Sariscak:

The Veterans Affairs Medical Center (VAMC) is proposing to install four new emission units (EUs) at the Perry Point Veterans Affairs Medical Center campus. This includes four (4) new diesel standby generators rated at 2,000 kW each and will provide emergency power, peak shaving, load shedding, and participation in demand response programs.

As part of this project, the facility will remove the existing two (2) diesel emergency generators rated at 2 MW each (MDE Registration No. 9-0100, 9-0200). These units will be permanently shut down and physically removed prior to operation of the new CAT 3516C Tier 4 generators.

A facility-wide potential-to-emit (PTE) evaluation was performed incorporating emissions from the proposed generators and all existing emission units at the facility. Based on enforceable operational limits of 250 hours per year per generator, the facility-wide PTE remains below the major source thresholds under the Title V Permit Program (COMAR 26.11.03) and below major source thresholds under the New Source Review (NSR) program.

VAMC is seeking coverage under Maryland's Minor New Source Review permitting program and intends to operate the proposed generators under Permits to Construct followed by Permits to Operate. It is VAMC's objective to maintain facility-wide emissions below major source thresholds and avoid the need for a synthetic minor permit or a Title V operating permit. This application package includes facility-wide PTE calculations, a detailed regulatory applicability analysis, and supporting documentation for MDE's review.

Pursuant to COMAR 26.11.02.11 we are submitting the Permit-to-Construct Application for Internal Combustion Engines with the following attachments:

- Vendor/manufacture specifications/guarantees
- Process flow diagrams with emission points
- Site plan including the location of the proposed EUs
- PTE calculations
- Manufacturer's Specification and Performance Data
- EPA Tier 4 Exhaust Emission Compliance Statement
- CPCN Exemption Letter from Maryland PSC

Perry Point VAMC verified with Cecil County Division of Planning and Zoning that, as a federal facility, VAMC is exempt from local land zoning regulations. Under Maryland Public Utilities Article, 7-207.1(d), the VA has delivered notice letters to all required officials within proximity to the proposed location of the generating station, as necessary.

Please address any questions concerning this submittal to my attention at 443-421-5449 or justin.raducha@va.gov, or Sierra Barr with EA Engineering, Science, and Technology, Inc., PBC at 478-308-7372 or sbarr@eaeast.com.

Sincerely,

Justin M. Raducha
Supervisory Healthcare Engineer
Perry Point VA Medical Center
Building 82, Room 221
Perry Point, MD 21902

Attachments

REGULATORY APPLICABILITY ANALYSIS

Diesel Standby Generators Permit to Construct Application

Prepared for

Perry Point Veterans Affairs Medical Center
10 N. Green Street,
Baltimore, MD 21201

Submitted to

Maryland Department of the Environment
Air and Radiation Management Administration
1800 Washington Boulevard
Baltimore, Maryland 21230-1718

Prepared by

EA Engineering, Science, and Technology, Inc., PBC
225 Schilling Circle
Hunt Valley, Maryland 21031

December 2025

CONTENTS

- I. Introduction
 - A. Project Description
 - B. Regulatory Applicability Analysis
- II. Application Forms
 - A. Cover Sheet and Checklist
 - B. Permit to Construct Application Forms
- III. Supporting Documentation
 - A. Vendor Specifications
 - B. Process Flow Diagram
 - C. General Location Map
 - D. Emissions Calculations
 - E. EPA Tier 4 Exhaust Emission Compliance
 - F. CPCN Exemption Approval Letter
 - G. Evidence of Workman's Compensation Insurance

SECTION I

INTRODUCTION

I. Introduction

Perry Point Veterans Affairs Medical Center proposes to install four (4) new diesel-fired standby generators at its existing campus located in Perry Point, Maryland. Each generator will have a rated electrical output of 2,000 kilowatts (kW). The generators will provide emergency backup power during utility outages and will also operate for non-emergency purposes including peak shaving, load shedding, and participation in demand response programs.

These units will be regulated as non-emergency stationary internal combustion engines for air quality permitting purposes. As such, their emissions associated with the proposed generators are included in the facility's total aggregated potential to emit (PTE) under both the federal Clean Air Act and Maryland air quality regulations.

A facility-wide PTE evaluation was conducted to assess the cumulative air emissions from the proposed generators in conjunction with all existing permitted and non-permitted emission units at the facility. The proposed generators will be subject to enforceable operating limits of no more than 250 hours per year per unit. Based on these enforceable limitations, the facility's total PTE remains below major source thresholds under both the New Source Review (NSR) preconstruction permitting program and the Title V operating permit program.

The proposed project will require a Minor NSR Permit to Construct (PTC) from the Maryland Department of the Environment (MDE), followed by issuance of Permits to Operate (PTO) for the new generators. It is the facility's objective to remain below major source thresholds and avoid the need for a synthetic minor permit or a Title V operating permit.

A. Project Description

The project consists of the installation of four (4) diesel-fired standby generators, each rated at 2,000 kW. The units will operate on ultra-low sulfur diesel (ULSD) fuel meeting federal sulfur content requirements.

B. Regulatory Applicability Analysis

This section summarizes the federal and state air quality regulations applicable to the proposed standby generator installation. The applicability of New Source Review (NSR), National Ambient Air Quality Standards (NAAQS), Prevention of Significant Deterioration (PSD), Title V, New Source Performance Standards (NSPS), National Emissions Standards for Hazardous Air Pollutants (NESHAP), and applicable Maryland COMAR regulations are discussed in this section.

1. New Source Review (NSR)

The federal New Source Review (NSR) program is comprised of two distinct preconstruction permitting programs: 1) Prevention of Significant Deterioration (PSD) for projects located in attainment areas; and 2) Nonattainment New Source Review (NNSR) for projects located in nonattainment areas.

PSD permitting may apply to facilities located in attainment areas for CAPs. Projects that are either new major stationary sources or modifications to existing major sources resulting in a significant emission increase and a significant net emission increase of an attainment pollutant are subject to the PSD permitting program.

NNSR permitting may apply to facilities located in areas that are designated in Title 40 of the Code of Federal Regulations Part 81 (40 CFR 81) as not in attainment with the National Ambient Air Quality Standard (NAAQS) for a specific criteria pollutant (i.e., areas referred to as nonattainment areas). Projects that are either new major stationary sources or modifications to existing major sources resulting in a significant emission increase and a significant net emission increase of a nonattainment pollutant are regulated under the NNSR program.

NAAQS Attainment Status

The Perry Point VAMC facility is located in Cecil County, Maryland, which is part of the Philadelphia-Wilmington-Atlantic City, and is part of the nonattainment area for the 2015 8-hour ozone standard (0.070 ppm), as designated by the EPA. The county is classified as serious nonattainment for ozone, while particulate matter, nitrogen dioxide, sulfur dioxide, carbon monoxide, and lead are designated as attainment and are not subject to nonattainment-area NSR requirements.

Prevention of Significant Deterioration (PSD)

The PSD program regulates emissions from “major” stationary sources of regulated pollutants (i.e., criteria pollutants). Under 40 CFR 51.166, a stationary source is classified as a PSD major source if it belongs to one of the 28 named source categories and has the potential to emit 100 tons per year (tpy) or more of any regulated pollutant; or has a PTE of 250 tpy or more of any regulated pollutant regardless of source category.

Perry Point VAMC does not belong to one of the 28 named PSD source categories. Facility-wide PTE calculations that include all existing equipment and the four proposed generators demonstrate emissions of all regulated pollutants remain below the 250-tpy major source threshold. Therefore, the proposed project does not trigger PSD permitting requirements.

Maryland Minor NSR Program

The Minor NSR program applies to a new minor source and/or a minor modification at both major and minor sources, in both attainment and nonattainment areas. The project involves the installation of new emission units that will increase potential emissions at the facility but will not result in a major source classification. The project is subject to Maryland's Minor NSR permitting program under COMAR 26.11.02. The facility is therefore required to obtain a PTC prior to the installation of the generators and a PTO following the completion of construction. A summary of annual PTE for criteria pollutants and hazardous air pollutants (HAPs) associated with the project is provided in Table 1. Detailed emissions calculations are included in the Supporting Documentation section of this application.

Table 1 - Generators PTE Summary

Emissions (units)	Pollutants						Total HAPs
	NO _x	VOC	CO	SO ₂	PM ₁₀ /PM _{2.5}	CO _{2e}	
tons/yr	6.47	0.74	8.09	0.02	0.15	1,597	0.042
lb/hr	51.76	5.88	64.72	0.14	1.16	12,772	0.334

As shown in Table 1, CAP and HAP PTE's are below major source thresholds.

Title V - Part 70 Operating Permit Program

The Title V operating permit program applies to major sources of criteria pollutants and hazardous air pollutants. Major source thresholds include 100 tpy (or 250 tpy depending on source classification) of any criteria pollutant, 10 tpy of any single HAP, or 25 tpy of any combination of HAPs. Based on facility-wide PTE calculations that include the proposed generators operating at enforceable limits of 250 hours per year per unit, the facility will remain a minor source of both criteria pollutants and HAPs. Accordingly, the facility is not subject to the Title V operating permit program at this time.

2. New Source Performance Standards (NSPS)

NSPS Subpart A - General Provisions

The General Provisions of 40 CFR Part 60 apply to any stationary source that contains an affected facility subject to a source-specific NSPS subpart.

NSPS Subpart IIII - Stationary Compression Ignition Internal Combustion Engines

NSPS Subpart IIII applies to stationary compression ignition internal combustion engines constructed or modified after July 11, 2005. The proposed generators meet the definition of affected facilities under this subpart and are therefore subject to its requirements.

Subpart IIII establishes emission limits for nitrogen oxides (NO_x), particulate matter (PM), carbon monoxide (CO) and hydrocarbons. The regulation imposes fuel sulfur content limits, compliance certification requirements, and operational recordkeeping and reporting provisions. Each proposed generator will be manufacturer-certified to meet the applicable Tier 4 emissions standards and will operate exclusively on ultra-low sulfur diesel fuel.

3. National Emission Standards for Hazardous Air Pollutants (NESHAP)

National Emission Standards for Hazardous Air Pollutants (NESHAP) are stationary source standards for HAPs. Sources subject to NESHAPs are required to perform an initial performance test to demonstrate compliance. To demonstrate continuous compliance, sources are generally required to monitor control device operating parameters which are established during the initial performance test. Sources may also be required to install and operate continuous emission monitors to demonstrate compliance. Consistent with EPA's Clean Air Act Stationary Source Compliance Monitoring Strategy, NESHAP sources that meet the Clean Air Act definition of "major source" generally receive a full compliance evaluation by the state or regional office at least once every two years.

NESHAP Subpart A - General Provisions

The General Provisions of 40 CFR Part 63 apply to any stationary source subject to a source-specific NESHAP standard.

NESHAP Subpart ZZZZ - Stationary Reciprocating Internal Combustion Engines

NESHAP Subpart ZZZZ applies to stationary reciprocating internal combustion engines. Since the proposed generators will operate for both emergency and non-emergency purposes, they are regulated as non-emergency stationary RICE engines under this subpart. Subpart ZZZZ establishes emission limits or management practice standards depending on engine size and classification and requires compliance with maintenance schedules, oil and filter change requirements, operating hour limitations, and recordkeeping and reporting obligations.

4. Maryland State Regulations:

The proposed generators are subject to applicable Maryland air quality regulations. The facility is also subject to all applicable State-only enforceable air control requirements including, but not limited to, the following regulations:

- COMAR 26.11.01 - General Administrative Provisions
- COMAR 26.11.02 - Permits, Approvals, and Registrations
- COMAR 26.11.03 - General Emission Standards and Title V Program

- COMAR 26.11.09 - Control of Fuel-Burning Equipment, Stationary Internal Combustion Engines
- COMAR 26.11.09.05 - Control of Visible Emissions
- COMAR 26.11.09.06 - Control of Particulate Matter
- COMAR 26.11.09.07 - Control of Sulfur Oxides from Fuel Burning Equipment
- COMAR 26.11.09.08 - Control of Nitrogen Oxides for Major Stationary Sources
- COMAR 26.11.15 - Control of Toxic Air Pollutants

SECTION II

APPLICATION FORMS

A. COVER SHEET AND CHECKLIST



AIR QUALITY PERMIT TO CONSTRUCT APPLICATION CHECKLIST

OWNER OF EQUIPMENT/PROCESS	
COMPANY NAME:	Veterans Affairs Medical Center
COMPANY ADDRESS:	10 N. Green Street, Baltimore, MD 21201
LOCATION OF EQUIPMENT/PROCESS	
PREMISES NAME:	Perry Point Veterans Medical Center
PREMISES ADDRESS:	Ward Circle, Perry Point, MD 21902
CONTACT INFORMATION FOR THIS PERMIT APPLICATION	
CONTACT NAME:	Justin M. Raducha
JOB TITLE:	Supervisory Healthcare Engineer
PHONE NUMBER:	443-421-5449
EMAIL ADDRESS:	justin.raducha@va.gov
DESCRIPTION OF EQUIPMENT OR PROCESS	
Installation of four (4) Caterpillar 3516C Diesel Generators, Rated at 2,000kW	

Application is hereby made to the Department of the Environment for a Permit to Construct for the following equipment or process as required by the State of Maryland Air Quality Regulation, COMAR 26.11.02.09.

Check each item that you have submitted as part of your application package.

- Application package cover letter describing the proposed project
- Complete application forms (Note the number of forms included or NA if not applicable.)

No. <u> 1 </u> Form 5	No. <u> N/A </u> Form 11
No. <u> N/A </u> Form 5T	No. <u> N/A </u> Form 41
No. <u> 4 </u> Form 5EP	No. <u> N/A </u> Form 42
No. <u> N/A </u> Form 6	No. <u> 1 </u> Form 44
No. <u> N/A </u> Form 10	
- Vendor/manufacturer specifications/guarantees
- Evidence of Workman's Compensation Insurance
- Process flow diagrams with emission points
- Site plan including the location of the proposed source and property boundary
- Material balance data and all emissions calculations
- Material Safety Data Sheets (MSDS) or equivalent information for materials processed and manufactured.
- Certificate of Public Convenience and Necessity (CPCN) waiver documentation from the Public Service Commission ⁽¹⁾
- Documentation that the proposed installation complies with local zoning and land use requirements ⁽²⁾

(1) Required for emergency and non-emergency generators installed on or after October 1, 2001 and rated at 2001 kW or more.

(2) Required for applications subject to Expanded Public Participation Requirements.

B. PERMIT-TO-CONSTRUCT APPLICATIONS

PROCESSING/MANUFACTURING EQUIPMENT (FORM 5)

MARYLAND DEPARTMENT OF THE ENVIRONMENT

Air and Radiation Administration • Air Quality Permits Program
 1800 Washington Boulevard • Baltimore, Maryland 21230
 (410) 537-3230 • 1-800-633-6101 • www.mde.maryland.gov

FORM 5 APPLICATION FOR PROCESSING OR MANUFACTURING EQUIPMENT/PROCESS

Permit to Construct
 Registration Update
 Initial Registration

1. Owner Information

Owner Name: Veterans Affairs Medical Center
 Owner Street Address: 10 N Green Street
 City/State/Zip Code: Baltimore MD 21201

2. Location of Equipment/Process

Check if different from above. If checked, complete the following:
 Premises Name: Perry Point
 Premises Street Address: Ward Circle
 City/State/Zip Code: Perry Point MD 21902

3. Contact Information

Contact Name: Justin Raducha
 Job Title: Supervisory Healthcare Engineer
 Phone Number: 443-421-5449
 Email Address: justin.raducha@va.gov

4. Workers' Compensation Coverage Information

Before a Permit to Construct may be issued by the Department, the applicant must provide the Department with proof of worker's compensation coverage as required under Section 1-202 of the Workers' Compensation Act.

Company Name: MEM Contracting, Inc.
 Binder/Policy Number: UB-0X393780-25-26-G Expiration Date: 09/01/2026

5. Person Installing Equipment/Process (if different from 1 above)

Installer Name and Title: MEM Contracting, Inc.
 Installer Company Name: MEM Contracting, Inc.
 Installer Street Address: 819 S. Philadelphia Blvd Suite C
 City/State/Zip Code: Aberdeen MD 21001
 Phone Number: 443-502-2824

6. Description of Major Activity, Product, or Service of Company at this Location (include applicable SIC code)

The facility is a federal Veterans Affairs Medical Center providing inpatient and outpatient medical services, emergency care, long-term care, and related health support functions (SIC Code: 8062)

7. Installation Type

New Equipment/Process
 Modification to Existing Equipment/Process
 Existing Equipment/Process

8. Projected Construction/Existing Operation Dates

Projected Construction Start Date: July 2025
 Projected Construction End Date: May 2026
 Projected Operating Date of New/Modified Equipment/Process: April 2026
 Existing Equipment/Process Initial Operating Date: N/A

9. Description of the Equipment/Process (include make, model, manufacturer, rated capacity, as applicable)

Four (4) Caterpillar diesel standby generators, Enging Model 3516C, maximum engine rating of 2914 hp, maximum electrical output of 2000 kW, tier 4 engines.

10. Supplemental Equipment/Process Information

Number of Pieces of Identical Equipment Units to be Registered/Permitted at this Time: 4
 Number of Stack/Emission Points Associated with the Equipment/Process: 4
 Fugitive Emissions Source? Yes No
 Note: Complete a Form 5EP for each stack/emission point or fugitive discharge area.

11. Control Devices Associated with this Equipment/Process

Note: Complete a Form 6 for each control device.

None Baghouse/Fabric Filter Cyclone Electrostatic Precipitator
 Dust Suppression Venturi Scrubber Adsorption System Spray Tower/Packed Bed
 Oxidizer Nitrogen Oxides Reduction Other, specify:

12. Fuel Consumption for this Equipment/Process

Natural Gas _____ 1000 cubic feet/year Coal (attach fuel specifications) _____ tons/year
 Propane/LP Gas _____ 100 gallons/year Wood (attach fuel specifications) _____ tons/year
 Distillate Fuel Oil 203 1000 gallons/year Other (describe): _____
 Residual Fuel Oil _____ 1000 gallons/year (specify units)

13. Operating Schedule for this Equipment/Process

<input type="checkbox"/> Continuous Operation <input checked="" type="checkbox"/> Batch Process _____ hours/batch _____ batches/week _____ operating hours/day _____ operating days/week Up to 250 hrs/year, per unit. _____ operating days/year	Seasonal Variation? <input type="checkbox"/> Yes <input checked="" type="checkbox"/> No If yes, complete the following: _____ Winter Percent _____ Spring Percent _____ Summer Percent _____ Fall Percent Total Seasons = 100% operating time
---	---

14. Input Materials and Usage Rates (attach additional materials as necessary)

Name of Input Material	CAS No. (if applicable)	Input Rate Per Hour	Identify Unit of Measure	Input Rate Per Year	Identify Unit of Measure
N/A - generators combust ultra-low sulfur diesel fuel only.					

15. Output Materials and Production Rates (attach additional materials as necessary)

Name of Output Material or Product	CAS No. (if applicable)	Output Rate Per Hour	Identify Unit of Measure	Output Rate Per Year	Identify Unit of Measure
N/A - generators do not produce a manufactured product.					

16. Waste Streams - Solid and Liquid (attach additional materials as necessary)

Name of Waste Material or Waste Product	CAS No. (if applicable)	Waste Generation Rate Per Hour	Identify Unit of Measure	Waste Generation Rate Per Year	Identify Unit of Measure
N/A - no process-related solid or liquid waste streams.					

17. Total Stack Emissions for this Equipment/Process

Nitrogen Oxides	94.56	lbs/operating day
Carbon Monoxide	19.44	lbs/operating day
Sulfur Oxides	0.8541	lbs/operating day
Particulate Matter (PM-10)	3.60	lbs/operating day
Particulate Matter (PM-2.5)	3.60	lbs/operating day
Volatile Organic Compounds	5.04	lbs/operating day
Greenhouse Gases (CO _{2e})	75,824.51	lbs/operating day

18. Total Fugitive Emissions for this Equipment/Process

Nitrogen Oxides	_____	lbs/operating day
Carbon Monoxide	_____	lbs/operating day
Sulfur Oxides	_____	lbs/operating day
Particulate Matter (PM-10)	_____	lbs/operating day
Particulate Matter (PM-2.5)	_____	lbs/operating day
Volatile Organic Compounds	_____	lbs/operating day
Greenhouse Gases (CO _{2e})	_____	lbs/operating day

19. Required Documents

Air Quality Permit to Construct Application Checklist - Include all required items on the checklist with the Form 5 application

Check this box if this application includes confidential information and submit one confidential copy of the application and one copy with all confidential information removed.

20. Responsible Party Certification Statement

"I CERTIFY UNDER PENALTY OF LAW THAT THE INFORMATION SUBMITTED IN THIS REQUEST FOR COVERAGE IS, TO THE BEST OF MY KNOWLEDGE AND BELIEF, TRUE, ACCURATE, AND COMPLETE. I AM AWARE THAT THERE ARE SIGNIFICANT PENALTIES FOR SUBMITTING FALSE INFORMATION, INCLUDING THE POSSIBILITY OF FINE AND IMPRISONMENT FOR KNOWING VIOLATIONS."

Responsible Party Signature _____

Date _____

Printed Name and Title _____

For ARA Use Only

Date Received:	
Date Reviewed:	
Reviewed By:	
ARA Premises Number:	
Associated ARA Registration Number or Numbers:	

EMISSION POINT DATA (FORM 5EP)

MARYLAND DEPARTMENT OF THE ENVIRONMENT
 Air and Radiation Management Administration • Air Quality Permits Program
 1800 Washington Boulevard • Baltimore, Maryland 21230
 (410)537-3230 • 1-800-633-6101 • www.mde.maryland.gov

FORM 5EP: Emission Point Data

Complete one (1) Form 5EP for EACH emission point (stack or fugitive emissions) related to the proposed installation.

Applicant Name: Perry Point VAMC

1. Emission Point Identification Name/Number

List the applicant assigned name/number for this emission point and use this value on the attached required plot plan:
EP01

2. Emission Point Description

Describe the emission point including all associated equipment and control devices:
Emissions associated with diesel generator.

3. Emissions Schedule for the Emission Point

Continuous or Intermittent (C/I)?	I	Seasonal Variation Check box if none: <input checked="" type="checkbox"/> Otherwise estimate seasonal variation:	
Minutes per hour:	0-60	Winter Percent	
Hours per day:	Intermittent	Spring Percent	
Days per week:	As-needed	Summer Percent	
Weeks per year:	250 hrs/year	Fall Percent	

4. Emission Point Information

Height above ground (ft):	TBD	Length and width dimensions at top of rectangular stack (ft):	Length:	Width:	
Height above structures (ft):	TBD		TBD	TBD	
Exit temperature (°F):	TBD	Inside diameter at top of round stack (ft):	TBD		
Exit velocity (ft/min):	TBD	Distance from emission point to nearest property line (ft):	TBD		
Exhaust gas volumetric flow rate (acfm):	TBD	Building dimensions if emission point is located on building (ft)	Height TBD	Length TBD	Width TBD

5. Control Devices Associated with the Emission Point

Identify each control device associated with the emission point and indicate the number of devices. **A Form 6 is also required for each control device.** If none check none:

- | | | | |
|---|-----------|--|--|
| <input checked="" type="checkbox"/> None | | <input type="checkbox"/> Thermal Oxidizer | No. _____ |
| <input type="checkbox"/> Baghouse | No. _____ | <input type="checkbox"/> Regenerative | |
| <input type="checkbox"/> Cyclone | No. _____ | <input type="checkbox"/> Catalytic Oxidizer | No. _____ |
| <input type="checkbox"/> Elec. Precipitator (ESP) | No. _____ | <input type="checkbox"/> Nitrogen Oxides Reduction | No. _____ |
| <input type="checkbox"/> Dust Suppression System | No. _____ | <input type="checkbox"/> Selective | <input type="checkbox"/> Non-Selective |
| <input type="checkbox"/> Venturi Scrubber | No. _____ | <input type="checkbox"/> Catalytic | <input type="checkbox"/> Non-Catalytic |
| <input type="checkbox"/> Spray Tower/Packed Bed | No. _____ | <input type="checkbox"/> Other | No. _____ |
| <input type="checkbox"/> Carbon Adsorber | No. _____ | Specify: | |
| <input type="checkbox"/> Cartridge/Canister | | | |
| <input type="checkbox"/> Regenerative | | | |

FORM 5EP: Emission Point Data

6. Estimated Emissions from the Emission Point

Criteria Pollutants	At Design Capacity (lb/hr)	At Projected Operations		
		(lb/hr)	(lb/day)	(ton/yr)
Particulate Matter (filterable as PM10)	*See attached			
Particulate Matter (filterable as PM2.5)				
Particulate Matter (condensables)				
Volatile Organic Compounds (VOC)				
Oxides of Sulfur (SOx)				
Oxides of Nitrogen (NOx)				
Carbon Monoxide (CO)				
Lead (Pb)				
Greenhouse Gases (GHG)	At Design Capacity (lb/hr)	At Projected Operations		
		(lb/hr)	(lb/day)	(ton/yr)
Carbon Dioxide (CO ₂)	*See attached			
Methane (CH ₄)				
Nitrous Oxide (N ₂ O)				
Hydrofluorocarbons (HFCs)				
Perfluorocarbons (PFCs)				
Sulfur Hexafluoride (SF ₆)				
Total GHG (as CO ₂ e)				
List individual federal Hazardous Air Pollutants (HAP) below:	At Design Capacity (lb/hr)	At Projected Operations		
		(lb/hr)	(lb/day)	(ton/yr)
*See attached				

(Attach additional sheets as necessary.)

MARYLAND DEPARTMENT OF THE ENVIRONMENT
 Air and Radiation Management Administration • Air Quality Permits Program
 1800 Washington Boulevard • Baltimore, Maryland 21230
 (410)537-3230 • 1-800-633-6101 • www.mde.maryland.gov

FORM 5EP: Emission Point Data

Complete one (1) Form 5EP for EACH emission point (stack or fugitive emissions) related to the proposed installation.

Applicant Name: Perry Point VAMC

1. Emission Point Identification Name/Number

List the applicant assigned name/number for this emission point and use this value on the attached required plot plan:
EP02

2. Emission Point Description

Describe the emission point including all associated equipment and control devices:
Emissions associated with diesel generator.

3. Emissions Schedule for the Emission Point

Continuous or Intermittent (C/I)?	I	Seasonal Variation Check box if none: <input checked="" type="checkbox"/> Otherwise estimate seasonal variation:	
Minutes per hour:	0-60	Winter Percent	
Hours per day:	Intermittent	Spring Percent	
Days per week:	As-needed	Summer Percent	
Weeks per year:	250 hrs/year	Fall Percent	

4. Emission Point Information

Height above ground (ft):	TBD	Length and width dimensions at top of rectangular stack (ft):	Length:	Width:	
Height above structures (ft):	TBD		TBD	TBD	
Exit temperature (°F):	TBD	Inside diameter at top of round stack (ft):	TBD		
Exit velocity (ft/min):	TBD	Distance from emission point to nearest property line (ft):	TBD		
Exhaust gas volumetric flow rate (acfm):	TBD	Building dimensions if emission point is located on building (ft)	Height TBD	Length TBD	Width TBD

5. Control Devices Associated with the Emission Point

Identify each control device associated with the emission point and indicate the number of devices. **A Form 6 is also required for each control device.** If none check none:

- | | | | |
|---|-----------|--|--|
| <input checked="" type="checkbox"/> None | | <input type="checkbox"/> Thermal Oxidizer | No. _____ |
| <input type="checkbox"/> Baghouse | No. _____ | <input type="checkbox"/> Regenerative | |
| <input type="checkbox"/> Cyclone | No. _____ | <input type="checkbox"/> Catalytic Oxidizer | No. _____ |
| <input type="checkbox"/> Elec. Precipitator (ESP) | No. _____ | <input type="checkbox"/> Nitrogen Oxides Reduction | No. _____ |
| <input type="checkbox"/> Dust Suppression System | No. _____ | <input type="checkbox"/> Selective | <input type="checkbox"/> Non-Selective |
| <input type="checkbox"/> Venturi Scrubber | No. _____ | <input type="checkbox"/> Catalytic | <input type="checkbox"/> Non-Catalytic |
| <input type="checkbox"/> Spray Tower/Packed Bed | No. _____ | <input type="checkbox"/> Other | No. _____ |
| <input type="checkbox"/> Carbon Adsorber | No. _____ | Specify: | |
| <input type="checkbox"/> Cartridge/Canister | | | |
| <input type="checkbox"/> Regenerative | | | |

FORM 5EP: Emission Point Data

6. Estimated Emissions from the Emission Point

Criteria Pollutants	At Design Capacity (lb/hr)	At Projected Operations		
		(lb/hr)	(lb/day)	(ton/yr)
Particulate Matter (filterable as PM10)	*See attached			
Particulate Matter (filterable as PM2.5)				
Particulate Matter (condensables)				
Volatile Organic Compounds (VOC)				
Oxides of Sulfur (SOx)				
Oxides of Nitrogen (NOx)				
Carbon Monoxide (CO)				
Lead (Pb)				
Greenhouse Gases (GHG)	At Design Capacity (lb/hr)	At Projected Operations		
		(lb/hr)	(lb/day)	(ton/yr)
Carbon Dioxide (CO ₂)	*See attached			
Methane (CH ₄)				
Nitrous Oxide (N ₂ O)				
Hydrofluorocarbons (HFCs)				
Perfluorocarbons (PFCs)				
Sulfur Hexafluoride (SF ₆)				
Total GHG (as CO ₂ e)				
List individual federal Hazardous Air Pollutants (HAP) below:	At Design Capacity (lb/hr)	At Projected Operations		
		(lb/hr)	(lb/day)	(ton/yr)
*See attached				

(Attach additional sheets as necessary.)

MARYLAND DEPARTMENT OF THE ENVIRONMENT
 Air and Radiation Management Administration • Air Quality Permits Program
 1800 Washington Boulevard • Baltimore, Maryland 21230
 (410)537-3230 • 1-800-633-6101 • www.mde.maryland.gov

FORM 5EP: Emission Point Data

Complete one (1) Form 5EP for EACH emission point (stack or fugitive emissions) related to the proposed installation.

Applicant Name: Perry Point VAMC

1. Emission Point Identification Name/Number

List the applicant assigned name/number for this emission point and use this value on the attached required plot plan:
EP03

2. Emission Point Description

Describe the emission point including all associated equipment and control devices:
Emissions associated with diesel generator.

3. Emissions Schedule for the Emission Point

Continuous or Intermittent (C/I)?	I	Seasonal Variation Check box if none: <input checked="" type="checkbox"/> Otherwise estimate seasonal variation:	
Minutes per hour:	0-60	Winter Percent	
Hours per day:	Intermittent	Spring Percent	
Days per week:	As-needed	Summer Percent	
Weeks per year:	250 hrs/year	Fall Percent	

4. Emission Point Information

Height above ground (ft):	TBD	Length and width dimensions at top of rectangular stack (ft):	Length:	Width:	
Height above structures (ft):	TBD		TBD	TBD	
Exit temperature (°F):	TBD	Inside diameter at top of round stack (ft):	TBD		
Exit velocity (ft/min):	TBD	Distance from emission point to nearest property line (ft):	TBD		
Exhaust gas volumetric flow rate (acfm):	TBD	Building dimensions if emission point is located on building (ft)	Height TBD	Length TBD	Width TBD

5. Control Devices Associated with the Emission Point

Identify each control device associated with the emission point and indicate the number of devices. **A Form 6 is also required for each control device.** If none check none:

- | | | | |
|---|-----------|--|--|
| <input checked="" type="checkbox"/> None | | <input type="checkbox"/> Thermal Oxidizer | No. _____ |
| <input type="checkbox"/> Baghouse | No. _____ | <input type="checkbox"/> Regenerative | |
| <input type="checkbox"/> Cyclone | No. _____ | <input type="checkbox"/> Catalytic Oxidizer | No. _____ |
| <input type="checkbox"/> Elec. Precipitator (ESP) | No. _____ | <input type="checkbox"/> Nitrogen Oxides Reduction | No. _____ |
| <input type="checkbox"/> Dust Suppression System | No. _____ | <input type="checkbox"/> Selective | <input type="checkbox"/> Non-Selective |
| <input type="checkbox"/> Venturi Scrubber | No. _____ | <input type="checkbox"/> Catalytic | <input type="checkbox"/> Non-Catalytic |
| <input type="checkbox"/> Spray Tower/Packed Bed | No. _____ | <input type="checkbox"/> Other | No. _____ |
| <input type="checkbox"/> Carbon Adsorber | No. _____ | Specify: | |
| <input type="checkbox"/> Cartridge/Canister | | | |
| <input type="checkbox"/> Regenerative | | | |

FORM 5EP: Emission Point Data

6. Estimated Emissions from the Emission Point

Criteria Pollutants	At Design Capacity (lb/hr)	At Projected Operations		
		(lb/hr)	(lb/day)	(ton/yr)
Particulate Matter (filterable as PM10)	*See attached			
Particulate Matter (filterable as PM2.5)				
Particulate Matter (condensables)				
Volatile Organic Compounds (VOC)				
Oxides of Sulfur (SOx)				
Oxides of Nitrogen (NOx)				
Carbon Monoxide (CO)				
Lead (Pb)				
Greenhouse Gases (GHG)	At Design Capacity (lb/hr)	At Projected Operations		
		(lb/hr)	(lb/day)	(ton/yr)
Carbon Dioxide (CO ₂)	*See attached			
Methane (CH ₄)				
Nitrous Oxide (N ₂ O)				
Hydrofluorocarbons (HFCs)				
Perfluorocarbons (PFCs)				
Sulfur Hexafluoride (SF ₆)				
Total GHG (as CO ₂ e)				
List individual federal Hazardous Air Pollutants (HAP) below:	At Design Capacity (lb/hr)	At Projected Operations		
		(lb/hr)	(lb/day)	(ton/yr)
*See attached				

(Attach additional sheets as necessary.)

MARYLAND DEPARTMENT OF THE ENVIRONMENT
 Air and Radiation Management Administration • Air Quality Permits Program
 1800 Washington Boulevard • Baltimore, Maryland 21230
 (410)537-3230 • 1-800-633-6101 • www.mde.maryland.gov

FORM 5EP: Emission Point Data

Complete one (1) Form 5EP for EACH emission point (stack or fugitive emissions) related to the proposed installation.

Applicant Name: Perry Point VAMC

1. Emission Point Identification Name/Number

List the applicant assigned name/number for this emission point and use this value on the attached required plot plan:
EP04

2. Emission Point Description

Describe the emission point including all associated equipment and control devices:
Emissions associated with diesel generator.

3. Emissions Schedule for the Emission Point

Continuous or Intermittent (C/I)?	I	Seasonal Variation Check box if none: <input checked="" type="checkbox"/> Otherwise estimate seasonal variation:	
Minutes per hour:	0-60	Winter Percent	
Hours per day:	Intermittent	Spring Percent	
Days per week:	As-needed	Summer Percent	
Weeks per year:	250 hrs/year	Fall Percent	

4. Emission Point Information

Height above ground (ft):	TBD	Length and width dimensions at top of rectangular stack (ft):	Length:	Width:	
Height above structures (ft):	TBD		TBD	TBD	
Exit temperature (°F):	TBD	Inside diameter at top of round stack (ft):		TBD	
Exit velocity (ft/min):	TBD	Distance from emission point to nearest property line (ft):		TBD	
Exhaust gas volumetric flow rate (acfm):	TBD	Building dimensions if emission point is located on building (ft)	Height TBD	Length TBD	Width TBD

5. Control Devices Associated with the Emission Point

Identify each control device associated with the emission point and indicate the number of devices. **A Form 6 is also required for each control device.** If none check none:

- | | | | |
|---|-----------|--|--|
| <input checked="" type="checkbox"/> None | | <input type="checkbox"/> Thermal Oxidizer | No. _____ |
| <input type="checkbox"/> Baghouse | No. _____ | <input type="checkbox"/> Regenerative | |
| <input type="checkbox"/> Cyclone | No. _____ | <input type="checkbox"/> Catalytic Oxidizer | No. _____ |
| <input type="checkbox"/> Elec. Precipitator (ESP) | No. _____ | <input type="checkbox"/> Nitrogen Oxides Reduction | No. _____ |
| <input type="checkbox"/> Dust Suppression System | No. _____ | <input type="checkbox"/> Selective | <input type="checkbox"/> Non-Selective |
| <input type="checkbox"/> Venturi Scrubber | No. _____ | <input type="checkbox"/> Catalytic | <input type="checkbox"/> Non-Catalytic |
| <input type="checkbox"/> Spray Tower/Packed Bed | No. _____ | <input type="checkbox"/> Other | No. _____ |
| <input type="checkbox"/> Carbon Adsorber | No. _____ | Specify: | |
| <input type="checkbox"/> Cartridge/Canister | | | |
| <input type="checkbox"/> Regenerative | | | |

FORM 5EP: Emission Point Data

6. Estimated Emissions from the Emission Point

Criteria Pollutants	At Design Capacity (lb/hr)	At Projected Operations		
		(lb/hr)	(lb/day)	(ton/yr)
Particulate Matter (filterable as PM10)	*See attached			
Particulate Matter (filterable as PM2.5)				
Particulate Matter (condensables)				
Volatile Organic Compounds (VOC)				
Oxides of Sulfur (SOx)				
Oxides of Nitrogen (NOx)				
Carbon Monoxide (CO)				
Lead (Pb)				
Greenhouse Gases (GHG)	At Design Capacity (lb/hr)	At Projected Operations		
		(lb/hr)	(lb/day)	(ton/yr)
Carbon Dioxide (CO ₂)	*See attached			
Methane (CH ₄)				
Nitrous Oxide (N ₂ O)				
Hydrofluorocarbons (HFCs)				
Perfluorocarbons (PFCs)				
Sulfur Hexafluoride (SF ₆)				
Total GHG (as CO ₂ e)				
List individual federal Hazardous Air Pollutants (HAP) below:	At Design Capacity (lb/hr)	At Projected Operations		
		(lb/hr)	(lb/day)	(ton/yr)
*See attached				

(Attach additional sheets as necessary.)

INTERNAL COMBUSTION ENGINES (FORM 44)

MARYLAND DEPARTMENT OF THE ENVIRONMENT

Air and Radiation Administration • Air Quality Permits Program
1800 Washington Boulevard • Baltimore, Maryland 21230
(410)537-3230 • 1-800-633-6101 • www.mde.maryland.gov

FORM 44

**STANDARD PERMIT TO CONSTRUCT APPLICATION FOR
INTERNAL COMBUSTION ENGINES**

1. Applicability for a Standard Permit to Construct for Internal Combustion Engines

- a. You **must** check off **one** of the following items to use this application form.
- This internal combustion engine is an electrical power generator that will be used for non-emergency electrical power generation (off grid, base load, peak shaving, load shaving, demand response).
 - This internal combustion engine is rated at 500 brake horsepower (373 kilowatts) or greater and used to directly power equipment (hydraulic, mechanical, etc.)
 - This internal combustion engine is rated at 500 brake horsepower (373 kilowatts) or greater and used as a fire pump engine.
- b. For electrical power generators only, you **must** check off **one** of the following items to use this application form.
- The generator set does not require a Certificate of Public Convenience and Necessity (CPCN) waiver from the Public Service Commission because the generator set was installed prior to October 1, 2001.
 - The generator set has received a CPCN waiver from the Public Service Commission.

2. Owner and Operator Information

Owner Name: Veterans Affairs Medical Center
Owner Street Address: 10 N Green Street
Owner City/State/Zip Code: Baltimore MD 21201

3. Location of the Internal Combustion Engine

Check if different from above. If checked, complete the following:
Premises Name: Perry Point Veterans Medical Center
Premises Street Address: Ward Circle
City/State/Zip Code: Perry Point MD 21902

4. Contact Information

Contact Name: Justin Raducha
Job Title: Supervisory Healthcare Engineer
Phone Number: 443-421-5449
Email Address: justin.raducha@va.gov

5. Workers' Compensation Coverage Information

Before a Permit to Construct may be issued by the Department, the applicant must provide the Department with proof of worker's compensation coverage as required under Section 1-202 of the Workers' Compensation Act.

Company Name: TBD
Binder/Policy Number: TBD | Expiration Date: TBD

6. Internal Combustion Engine Description

Date of Installation TBD
Number of Identical Units Installed 4
Number of Units Removed (describe, include ARA Registration Number if applicable) _____

Engine Information

Engine Make Caterpillar Engine Model No. 3516C
Engine Manufacture Date TBD Engine Model Year 2019
Maximum Engine Rating in Horsepower 2941 hp Maximum Electrical Output in Kilowatts 2000
Fuel Type Diesel
U.S. EPA Certified Tier Rating for the Engine (if applicable): 4

7. Operating Schedule

Hours per Day: intermittent
Days per Week: as-needed
Days per Year: up to 250 hrs/yr

FORM 44
STANDARD PERMIT TO CONSTRUCT APPLICATION FOR
INTERNAL COMBUSTION ENGINES

8. Required Supplemental Documents

- Engine Manufacturer Literature/Engine Specification Sheet
- A copy of the engine Certificate of Conformity or other evidence showing that the engine is certified to meet U.S. EPA Tier standards for non-emergency engines (if applicable)
- Form 5EP for each engine stack emission point
- Form 6 for each air pollution control device (if applicable)
- Emissions estimates for the engine

9. Responsible Party Certification Statement

"I CERTIFY UNDER PENALTY OF LAW THAT THE INFORMATION SUBMITTED IN THIS REQUEST FOR COVERAGE IS, TO THE BEST OF MY KNOWLEDGE AND BELIEF, TRUE, ACCURATE, AND COMPLETE. I AM AWARE THAT THERE ARE SIGNIFICANT PENALTIES FOR SUBMITTING FALSE INFORMATION, INCLUDING THE POSSIBILITY OF FINE AND IMPRISONMENT FOR KNOWING VIOLATIONS."

Responsible Party Signature

Date

Printed Name and Title

For ARA Use Only

Date Received:	
Date Reviewed:	
Reviewed By:	
ARA Premises Number:	
Associated ARA Registration Number or Numbers:	

SECTION III
SUPPORTING DOCUMENTATION

A. VENDOR/MANUFACTURER SPECIFICATIONS/GUARANTEES

Cat® 3516C

Diesel Generator Sets



Image shown may not reflect actual configuration

Bore – mm (in)	170 (6.69)
Stroke – mm (in)	215 (8.46)
Displacement – L (in ³)	78 (4764.73)
Compression Ratio	14.7:1
Aspiration	TA
Fuel System	EUI
Governor Type	ADEM™ A3

Standby 60 Hz ekW (kVA)	Mission Critical 60 Hz ekW (kVA)	Prime 60 Hz ekW (kVA)	Emissions Performance
2000 (2500)	2000 (2500)	1825 (2281)	U.S. EPA Tier 4 Final

Standard Features

Cat® Diesel Engine

- Meets U.S. EPA Tier 4 Final emission standards
- Reliable performance proven in thousands of applications worldwide

Generator Set Package

- Accepts 100% block load in one step and meets other NFPA 110 loading requirements
- Conforms to ISO 8528-5 G3 load acceptance requirements
- Reliability verified through torsional vibration, fuel consumption, oil consumption, transient performance, and endurance testing

Alternators

- Superior motor starting capability minimizes need for oversizing generator
- Designed to match performance and output characteristics of Cat diesel engines

Cooling System

- Cooling systems available to operate in ambient temperatures up to 50°C (122°F)
- Tested to ensure proper generator set cooling

Clean Emissions Module

- Diesel oxidation catalyst for particulate matter (PM) and hydrocarbon (HC) control
- Selective catalytic reduction (SCR) for nitrogen oxides (NOx) control
- Integrated electronics for monitoring, protection, and closed loop NOx control

EMCP 4 Control Panels

- User-friendly interface and navigation
- Scalable system to meet a wide range of installation requirements
- Expansion modules and site specific programming for specific customer requirements

Warranty

- 24 months/1000-hour warranty for standby and mission critical ratings
- 12 months/unlimited hour warranty for prime and continuous ratings
- Extended service protection is available to provide extended coverage options

Worldwide Product Support

- Cat dealers have over 1,800 dealer branch stores operating in 200 countries
- Your local Cat dealer provides extensive post-sale support, including maintenance and repair agreements

Financing

- Caterpillar offers an array of financial products to help you succeed through financial service excellence
- Options include loans, finance lease, operating lease, working capital, and revolving line of credit
- Contact your local Cat dealer for availability in your region

Optional Equipment

Engine

Air Cleaner

- Single element
- Dual element

Muffler

- Industrial grade (12 dB)

Starting

- Standard batteries
- Oversized batteries
- Standard electric starter(s)
- Heavy duty electric starter(s)
- Air starter(s)
- Jacket water heater

Alternator

Output voltage

- 480V 6600V
- 600V 6900V
- 2400V 12470V
- 4160V 13200V
- 6300V 13800V

Temperature Rise (over 40°C ambient)

- 150°C
- 125°C/130°C
- 105°C
- 80°C

Winding type

- Random wound
- Form wound

Excitation

- Self excited
- Internal excitation (IE)
- Permanent magnet (PM)

Attachments

- Anti-condensation heater
- Stator and bearing temperature monitoring and protection

Power Termination

Type

- Bus bar
- Circuit breaker
- 1600A 2000A
- 2500A 3000A
- 3200A 4000A
- 5000A
- UL IEC
- 3-pole 4-pole
- Manually operated
- Electrically operated

Trip Unit

- LSI LSI-G
- LSIG-P

Control System

Controller

- EMCP 4.3
- EMCP 4.4

Attachments

- Local annunciator module
- Remote annunciator module
- Expansion I/O module
- Remote monitoring software

Charging

- Battery charger – 10A
- Battery charger – 20A
- Battery charger – 35A

Vibration Isolators

- Rubber
- Spring
- Seismic rated

Cat Connect

Connectivity

- Ethernet
- Cellular
- Satellite

Extended Service Options

Terms

- 2 year (prime)
- 3 year
- 5 year
- 10 year

Coverage

- Silver
- Gold
- Platinum
- Platinum Plus

Ancillary Equipment

- Automatic transfer switch (ATS)
- Uninterruptible power supply (UPS)
- Paralleling switchgear
- Paralleling controls

Certifications

- IBC seismic certification
- OSHPD pre-approval

Note: Some options may not be available on all models. Certifications may not be available with all model configurations. Consult factory for availability.

Package Performance

Performance	Standby		Mission Critical		Prime	
Frequency	60 Hz		60 Hz		60 Hz	
Gen set power rating with fan	2000 ekW		2000 ekW		1825 ekW	
Gen set power rating with fan @ 0.8 power factor	2500 kVA		2500 kVA		2281 kVA	
Emissions	Tier 4 Final		Tier 4 Final		Tier 4 Final	
Performance number	DM9368-01		DM9300-01		DM9369-01	
Fuel Consumption						
100% load with fan – L/hr (gal/hr)	528.0	(139.5)	528.0	(139.5)	484.6	(128.8)
75% load with fan – L/hr (gal/hr)	409.8	(108.3)	409.8	(108.3)	382.2	(101.0)
50% load with fan – L/hr (gal/hr)	297.0	(78.5)	297.0	(78.5)	277.8	(73.4)
25% load with fan – L/hr (gal/hr)	181.3	(47.9)	181.3	(47.9)	172.7	(45.6)
Diesel Exhaust Fluid (DEF) Consumption						
100% load with fan – L/hr (gal/hr)	38.2	(10.1)	38.2	(10.1)	33.7	(8.9)
75% load with fan – L/hr (gal/hr)	25.0	(6.6)	25.0	(6.6)	21.2	(5.6)
50% load with fan – L/hr (gal/hr)	13.2	(3.5)	13.2	(3.5)	12.1	(3.2)
25% load with fan – L/hr (gal/hr)	6.1	(1.6)	6.1	(1.6)	5.7	(1.5)
Cooling System						
Radiator air flow restriction (system) – kPa (in. water)	0.12	(0.48)	0.12	(0.48)	0.12	(0.48)
Radiator air flow – m ³ /min (cfm)	2661.0	(93972)	2661.0	(93972)	2661.0	(93972)
Engine coolant capacity – L (gal)	233.0	(61.6)	233.0	(61.6)	233.0	(61.6)
Radiator coolant capacity – L (gal)	238.5	(63.0)	238.5	(63.0)	238.5	(63.0)
Total coolant capacity – L (gal)	471.5	(124.6)	471.5	(124.6)	471.5	(124.6)
Inlet Air						
Combustion air inlet flow rate – m ³ /min (cfm)	172.7	(6097.7)	172.7	(6097.7)	161.9	(5716.6)
Exhaust System						
Exhaust stack gas temperature – °C (°F)	493.7	(920.6)	493.7	(920.6)	487.8	(910.0)
Exhaust gas flow rate – m ³ /min (cfm)	461.7	(16301.3)	461.7	(16301.3)	427.5	(15095.5)
Exhaust system backpressure (maximum allowable) – kPa (in. water)	6.0	(24.0)	6.0	(24.0)	6.0	(24.0)
CEM outlet temperature – °C (°F)	476.9	(890.5)	476.9	(890.5)	469.4	(876.9)
Heat Rejection						
Heat rejection to jacket water – kW (Btu/min)	705	(40104)	705	(40104)	663	(37690)
Heat rejection to exhaust (total) – kW (Btu/min)	2070	(117743)	2070	(117743)	1905	(108311)
Heat rejection to aftercooler – kW (Btu/min)	487	(27713)	487	(27713)	422	(24018)
Heat rejection to atmosphere from engine – kW (Btu/min)	151	(8584)	151	(8584)	146	(8304)
Heat rejection to atmosphere from CEM – kW (Btu/min)	85	(4826)	85	(4826)	86	(4886)
Heat rejection from alternator – kW (Btu/min)	96	(5482)	96	(5482)	86	(4891)

Weights and Dimensions

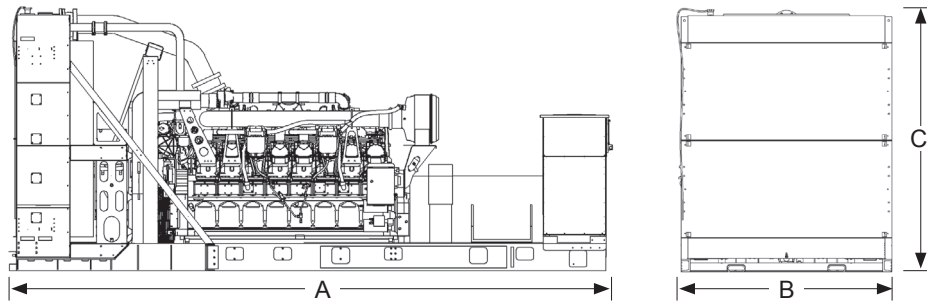

Dim "A" mm (in)	Dim "B" mm (in)	Dim "C" mm (in)	Dry Weight kg (lb)
6796.6 (267.6)	2378.7 (93.7)	2964.8 (116.7)	16 874 (37,200)

Note: For reference only. Do not use for installation design. Contact your local Cat dealer for precise weights and dimensions.

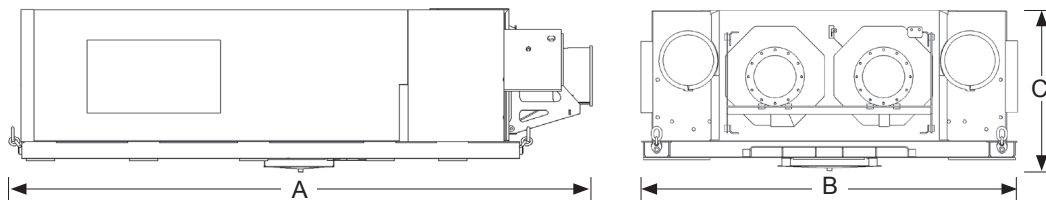

Dim "A" mm (in)	Dim "B" mm (in)	Dim "C" mm (in)	Dry Weight kg (lb)
3446.3 (135.7)	1537.3 (60.5)	895.1 (35.2)	2064 (4550)

Ratings Definitions

Standby

Output available with varying load for the duration of the interruption of the normal source power. Average power output is 70% of the standby power rating. Typical operation is 200 hours per year, with maximum expected usage of 500 hours per year.

Mission Critical

Output available with varying load for the duration of the interruption of the normal source power. Average power output is 85% of the mission critical power rating. Typical peak demand up to 100% of rated power for up to 5% of the operating time. Typical operation is 200 hours per year, with maximum expected usage of 500 hours per year.

Prime

Output available with varying load for an unlimited time. Average power output is 70% of the prime power rating. Typical peak demand is 100% of prime rated kW with 10% overload capability for emergency use for a maximum of 1 hour in 12. Overload operation cannot exceed 25 hours per year.

Applicable Codes and Standards

AS 1359, CSA C22.2 No. 100-04, UL 142, UL 489, UL 869, UL 2200, NFPA37, NFPA70, NFPA99, NFPA110, IBC, IEC 60034-1, ISO 3046, ISO 8528, NEMA MG1-22, NEMA MG1-33, 2014/35/EU, 2006/42/EC, 2014/30/EU.

Note: Codes may not be available in all model configurations. Please consult your local Cat dealer for availability.

Data Center Applications

Tier III/Tier IV compliant per Uptime Institute requirements. ANSI/TIA-942 compliant for Rated-1 through Rated-4 data centers.

Fuel Rates

Fuel rates are based on fuel oil of 35° API [16°C (60°F)] gravity having an LHV of 42,780 kJ/kg (18,390 Btu/lb) when used at 29°C (85°F) and weighing 838.9 g/liter (7.001 lbs/U.S. gal.)

www.cat.com/electricpower

©2018 Caterpillar
 All rights reserved.

Materials and specifications are subject to change without notice. The International System of Units (SI) is used in this publication.

CAT, CATERPILLAR, their respective logos, ADEM, "Caterpillar Yellow", the "Power Edge" trade dress as well as corporate and product identity used herein, are trademarks of Caterpillar and may not be used without permission.

PERFORMANCE DATA [516DRJ9]**APRIL 26, 2019**For Help Desk Phone Numbers [Click here](#)

Perf No: DM9368

Change Level: 02

[General](#)
[Heat Rejection](#)
[Sound Emissions](#)
[Regulatory](#)
[Altitude Derate](#)
[Cross Reference](#)
[Supplementary Data](#)
[Perf Param Ref](#)

View PDF

SALES MODEL:	3516C	COMBUSTION:	DIRECT INJECTION
BRAND:	CAT	ENGINE SPEED (RPM):	1,800
ENGINE POWER (BHP):	2,944	HERTZ:	60
GEN POWER WITH FAN (EKW):	2,000.0	FAN POWER (HP):	130.1
COMPRESSION RATIO:	14	ASPIRATION:	TA
RATING LEVEL:	STANDBY	AFTERCOOLER TYPE:	ATAAC
PUMP QUANTITY:	1	AFTERCOOLER CIRCUIT TYPE:	JW+OC, ATAAC
FUEL TYPE:	DIESEL	INLET MANIFOLD AIR TEMP (F):	113
MANIFOLD TYPE:	DRY	JACKET WATER TEMP (F):	210.2
GOVERNOR TYPE:	ADEM4	TURBO CONFIGURATION:	PARALLEL
ELECTRONICS TYPE:	ADEM4	TURBO QUANTITY:	4
CAMSHAFT TYPE:	STANDARD	TURBOCHARGER MODEL:	GTB6041BN-48T-1.04
IGNITION TYPE:	CI	CERTIFICATION YEAR:	2011
INJECTOR TYPE:	EUI	FUEL RATE (RATED RPM) NO LOAD (GAL/HR):	16.4
REF EXH STACK DIAMETER (IN):	12	PISTON SPD @ RATED ENG SPD (FT/MIN):	2,539.4

INDUSTRY	SUB INDUSTRY	APPLICATION
OIL AND GAS	LAND PRODUCTION	PACKAGED GENSET
ELECTRIC POWER	STANDARD	PACKAGED GENSET

General Performance Data [Top](#)**Note(s)**

THE INLET MANIFOLD AIR TEMP LISTED IN THE HEADER, AND IN THE GENERAL PERFORMANCE DATA, IS THE AVERAGE INLET MANIFOLD TEMP FRONT TO REAR ON THE ENGINE.

GENSET POWER WITH FAN	PERCENT LOAD	ENGINE POWER	BRAKE MEAN EFF PRES (BMEP)	BRAKE SPEC FUEL CONSUMPTN (BSFC)	VOL FUEL CONSUMPTN (VFC)	INLET MFLD PRES	INLET MFLD TEMP	EXH MFLD TEMP	EXH MFLD PRES	ENGINE OUTLET TEMP
EKW	%	BHP	PSI	LB/BHP-HR	GAL/HR	IN-HG	DEG F	DEG F	IN-HG	DEG F
2,000.0	100	2,941	272	0.332	139.4	58.4	111.5	1,204.7	49.7	916.8
1,800.0	90	2,660	246	0.333	126.4	51.5	108.3	1,175.1	44.3	910.4
1,600.0	80	2,382	220	0.335	114.0	45.0	105.5	1,144.6	39.3	898.3
1,500.0	75	2,243	207	0.337	108.1	42.0	104.3	1,129.6	37.0	891.6
1,400.0	70	2,104	194	0.341	102.4	39.4	103.4	1,114.9	34.9	884.8
1,200.0	60	1,828	169	0.350	91.3	34.3	102.1	1,086.2	31.1	869.9
1,000.0	50	1,552	143	0.354	78.5	27.6	99.2	1,039.8	26.3	841.7
800.0	40	1,282	118	0.361	66.1	21.5	98.6	981.3	21.9	807.4
600.0	30	1,010	93	0.375	54.1	16.1	97.7	904.6	18.2	760.3
500.0	25	872	81	0.384	47.8	13.4	96.3	850.1	16.2	717.9
400.0	20	731	67	0.392	40.9	10.3	94.7	778.0	13.9	657.1
200.0	10	438	40	0.445	27.8	5.6	92.5	616.7	10.5	529.7

GENSET POWER WITH FAN	PERCENT LOAD	ENGINE POWER	COMPRESSOR OUTLET PRES	COMPRESSOR OUTLET TEMP	WET INLET AIR VOL FLOW RATE	ENGINE OUTLET WET EXH GAS VOL FLOW RATE	WET INLET AIR MASS FLOW RATE	WET EXH GAS MASS FLOW RATE	WET EXH VOL FLOW RATE (32 DEG F AND 29.98 IN HG)	DRY EXH VOL FLOW RATE (32 DEG F AND 29.98 IN HG)
EKW	%	BHP	IN-HG	DEG F	CFM	CFM	LB/HR	LB/HR	FT3/MIN	FT3/MIN
2,000.0	100	2,941	63	370.0	6,117.8	16,296.7	26,679.4	27,655.5	5,821.1	5,313.4
1,800.0	90	2,660	56	346.3	5,649.7	14,919.1	24,540.7	25,426.4	5,353.9	4,890.6
1,600.0	80	2,382	49	322.3	5,233.5	13,623.3	22,636.4	23,434.5	4,932.6	4,514.1
1,500.0	75	2,243	46	310.4	5,044.5	13,036.8	21,779.2	22,536.4	4,743.5	4,345.6
1,400.0	70	2,104	43	299.9	4,872.6	12,509.4	21,010.6	21,728.4	4,574.6	4,195.7
1,200.0	60	1,828	38	278.9	4,529.8	11,461.7	19,497.9	20,136.8	4,238.6	3,897.3
1,000.0	50	1,552	31	249.0	4,081.8	10,058.8	17,503.2	18,052.8	3,800.4	3,505.0
800.0	40	1,282	24	220.0	3,648.3	8,709.5	15,591.9	16,054.7	3,379.6	3,128.5
600.0	30	1,010	18	191.9	3,264.0	7,477.9	13,930.3	14,309.0	3,013.6	2,804.2
500.0	25	872	16	176.6	3,074.2	6,792.8	13,112.0	13,446.6	2,836.3	2,648.4
400.0	20	731	12	158.5	2,849.6	5,937.6	12,132.8	12,419.2	2,614.1	2,450.9
200.0	10	438	7	131.6	2,527.3	4,684.4	10,754.6	10,949.4	2,327.8	2,206.2

Heat Rejection Data [Top](#)

Note(s)

HEAT REJECTION TO ATMOSPHERE SHOWN HERE IS ENGINE ONLY. CEM HEAT REJECTION TO ATMOSPHERE SHOWN IN THE SUPPLEMENTARY DATA IS THE ADDITIONAL HEAT REJECTED TO ATMOSPHERE FROM THE CEM. THIS ADDITIONAL HEAT IS INCLUDED IN THE HEAT REJECTION TO EXH AND EXH RECOVERY SHOWN HERE AND WOULD NEED TO BE DEDUCTED FROM THE EXH AND EXH RECOVERY VALUES WHEN SIZING EXHAUST RECOVERY HEAT EQUIPMENT.

GENSET POWER WITH FAN	PERCENT LOAD	ENGINE POWER	REJECTION TO JACKET WATER	REJECTION TO ATMOSPHERE	REJECTION TO EXH	EXHAUST RECOVERY TO 350F	FROM OIL COOLER	FROM AFTERCOOLER	WORK ENERGY	LOW HEAT VALUE ENERGY	HIGH HEAT VALUE ENERGY
EKW	%	BHP	BTU/MIN	BTU/MIN	BTU/MIN	BTU/MIN	BTU/MIN	BTU/MIN	BTU/MIN	BTU/MIN	BTU/MIN
2,000.0	100	2,941	40,137	8,595	117,592	66,550	15,934	27,755	124,739	299,165	318,686
1,800.0	90	2,660	37,265	8,230	107,071	60,439	14,452	23,576	112,812	271,341	289,046
1,600.0	80	2,382	34,765	7,921	96,968	54,405	13,027	19,880	100,998	244,583	260,543
1,500.0	75	2,243	33,626	7,807	92,267	51,635	12,352	18,062	95,121	231,910	247,042
1,400.0	70	2,104	32,494	7,660	88,043	49,106	11,709	16,552	89,226	219,828	234,172
1,200.0	60	1,828	30,269	7,310	79,707	44,130	10,432	13,963	77,505	195,863	208,643
1,000.0	50	1,552	27,435	6,926	68,593	37,291	8,972	10,585	65,823	168,453	179,445
800.0	40	1,282	24,601	6,521	58,060	30,727	7,559	7,637	54,383	141,923	151,184
600.0	30	1,010	21,553	6,025	47,781	24,426	6,182	5,286	42,840	116,063	123,636
500.0	25	872	20,101	5,692	42,164	20,481	5,460	4,213	36,971	102,516	109,205
400.0	20	731	18,971	5,327	35,071	15,693	4,675	3,089	30,983	87,777	93,505
200.0	10	438	14,511	4,702	24,157	7,981	3,182	1,703	18,564	59,734	63,631

Sound Data [Top](#)

Note(s)

SOUND DATA REPRESENTATIVE OF NOISE PRODUCED BY THE "ENGINE AND CEM" AS A UNIT WITHOUT A MUFFLER INSTALLED

EXHAUST: Sound Power (1/3 Octave Frequencies)

GENSET POWER WITH FAN	PERCENT LOAD	ENGINE POWER	OVERALL SOUND	100 HZ	125 HZ	160 HZ	200 HZ	250 HZ	315 HZ	400 HZ	500 HZ	630 HZ	800 HZ
EKW	%	BHP	dB(A)	dB(A)	dB(A)	dB(A)	dB(A)	dB(A)	dB(A)	dB(A)	dB(A)	dB(A)	dB(A)
2,000.0	100	2,941	97.8	68.7	75.2	74.3	82.8	87.5	87.1	84.5	88.6	88.2	91.2
1,800.0	90	2,660	95.8	67.9	74.7	72.8	80.9	85.7	85.4	83.1	86.6	86.1	88.8
1,600.0	80	2,382	94.0	67.4	74.6	71.3	79.2	84.1	84.0	82.4	85.0	84.3	86.7
1,500.0	75	2,243	93.2	67.2	74.7	70.6	78.4	83.4	83.5	82.1	84.2	83.4	85.6

GENSET POWER WITH FAN	PERCENT LOAD	ENGINE POWER	OVERALL SOUND	100 HZ	125 HZ	160 HZ	200 HZ	250 HZ	315 HZ	400 HZ	500 HZ	630 HZ	800 HZ
1,400.0	70	2,104	92.3	67.0	74.7	69.8	77.5	82.7	82.8	81.8	83.4	82.5	84.6
1,200.0	60	1,828	90.7	66.6	74.9	68.3	75.7	81.2	81.5	81.3	81.8	80.8	82.6
1,000.0	50	1,552	89.4	64.9	75.8	67.5	74.6	79.5	79.8	80.5	80.4	79.6	81.1
800.0	40	1,282	88.0	65.1	75.5	65.7	72.7	78.2	78.9	80.2	78.9	77.6	78.8
600.0	30	1,010	86.6	64.6	75.5	64.9	70.8	76.6	77.4	79.4	77.3	75.9	76.8
500.0	25	872	86.2	62.8	76.3	65.9	70.4	75.4	75.9	78.6	76.4	75.6	76.5
400.0	20	731	85.9	60.9	77.1	67.0	70.1	74.4	74.5	77.8	75.5	75.5	76.4
200.0	10	438	85.8	60.5	77.3	67.2	70.0	74.2	74.2	77.6	75.3	75.5	76.3

EXHAUST: Sound Power (1/3 Octave Frequencies)

GENSET POWER WITH FAN	PERCENT LOAD	ENGINE POWER	1000 HZ	1250 HZ	1600 HZ	2000 HZ	2500 HZ	3150 HZ	4000 HZ	5000 HZ	6300 HZ	8000 HZ	10000 HZ
EKW	%	BHP	dB(A)	dB(A)	dB(A)	dB(A)	dB(A)	dB(A)	dB(A)	dB(A)	dB(A)	dB(A)	dB(A)
2,000.0	100	2,941	90.3	85.2	82.8	79.8	77.1	73.8	69.3	63.6	63.3	55.1	61.1
1,800.0	90	2,660	87.9	82.9	80.7	77.9	75.4	72.0	67.7	62.3	62.1	55.2	61.1
1,600.0	80	2,382	85.5	80.4	78.5	76.3	74.0	70.6	66.5	61.7	61.7	55.6	58.4
1,500.0	75	2,243	84.3	79.1	77.4	75.6	73.3	70.0	66.0	61.5	61.6	56.0	56.6
1,400.0	70	2,104	83.1	77.9	76.3	74.9	72.6	69.3	65.5	61.3	61.5	56.3	54.9
1,200.0	60	1,828	80.7	75.5	74.1	73.5	71.2	67.9	64.5	60.9	61.3	57.0	51.4
1,000.0	50	1,552	79.5	74.8	73.0	73.1	70.8	67.4	63.5	60.8	61.4	55.0	49.7
800.0	40	1,282	76.6	71.5	70.3	71.3	69.0	65.7	62.5	60.2	61.1	56.8	45.4
600.0	30	1,010	74.2	69.3	68.4	69.9	67.7	64.5	61.7	59.8	60.8	57.3	42.4
500.0	25	872	74.5	70.6	69.2	70.2	68.2	65.0	61.6	59.9	60.9	54.2	43.5
400.0	20	731	75.0	72.2	70.2	70.8	68.9	65.6	61.5	60.1	61.0	51.2	45.0
200.0	10	438	75.1	72.5	70.4	70.9	69.0	65.7	61.5	60.1	61.0	50.5	45.2

MECHANICAL: Sound Power (1/3 Octave Frequencies)

GENSET POWER WITH FAN	PERCENT LOAD	ENGINE POWER	OVERALL SOUND	100 HZ	125 HZ	160 HZ	200 HZ	250 HZ	315 HZ	400 HZ	500 HZ	630 HZ	800 HZ
EKW	%	BHP	dB(A)	dB(A)	dB(A)	dB(A)	dB(A)	dB(A)	dB(A)	dB(A)	dB(A)	dB(A)	dB(A)
2,000.0	100	2,941	123.0	89.3	107.2	96.2	99.4	100.3	102.8	101.0	105.5	106.8	108.7
1,800.0	90	2,660	122.2	88.6	106.6	95.4	98.5	99.4	102.5	100.9	105.4	106.5	108.6
1,600.0	80	2,382	121.4	88.1	106.0	94.6	97.5	98.5	102.0	100.9	104.7	106.1	108.6
1,500.0	75	2,243	121.1	88.0	105.7	94.1	97.0	98.1	101.8	100.8	104.2	106.0	108.6
1,400.0	70	2,104	120.8	87.8	105.4	93.5	96.3	97.5	101.4	100.5	103.8	105.9	108.4
1,200.0	60	1,828	120.3	87.7	104.7	92.0	94.5	96.2	100.4	99.7	103.4	106.1	107.7
1,000.0	50	1,552	119.9	87.8	104.3	91.0	93.7	95.8	99.7	101.4	103.4	106.2	107.3
800.0	40	1,282	119.5	87.9	103.9	90.9	93.3	95.6	98.5	101.6	103.9	106.0	107.7
600.0	30	1,010	119.3	87.6	103.4	90.9	93.6	95.3	97.8	100.6	105.1	106.1	108.3
500.0	25	872	119.1	87.1	103.3	90.5	94.3	95.2	98.2	100.3	105.9	106.6	108.6
400.0	20	731	119.0	86.5	103.1	90.2	94.9	95.0	98.8	100.2	106.6	107.1	109.0
200.0	10	438	119.0	85.8	102.4	90.0	94.7	95.5	99.2	101.4	106.4	107.7	109.7

MECHANICAL: Sound Power (1/3 Octave Frequencies)

GENSET POWER WITH FAN	PERCENT LOAD	ENGINE POWER	1000 HZ	1250 HZ	1600 HZ	2000 HZ	2500 HZ	3150 HZ	4000 HZ	5000 HZ	6300 HZ	8000 HZ	10000 HZ
EKW	%	BHP	dB(A)	dB(A)	dB(A)	dB(A)	dB(A)	dB(A)	dB(A)	dB(A)	dB(A)	dB(A)	dB(A)
2,000.0	100	2,941	112.2	113.0	111.8	111.5	110.6	110.0	109.1	108.6	107.3	106.4	117.7
1,800.0	90	2,660	112.1	112.5	111.3	111.2	110.3	109.7	108.8	108.3	106.8	106.2	115.9
1,600.0	80	2,382	111.8	111.9	110.9	110.7	109.8	109.2	108.2	107.8	106.2	106.4	113.6
1,500.0	75	2,243	111.6	111.6	110.7	110.3	109.6	109.0	107.9	107.5	105.9	106.8	112.4
1,400.0	70	2,104	111.4	111.3	110.5	109.9	109.4	108.7	107.5	107.2	105.7	108.0	110.7
1,200.0	60	1,828	111.1	110.8	110.3	109.5	109.0	108.2	106.9	106.6	105.4	111.2	106.5
1,000.0	50	1,552	110.9	110.7	110.0	109.4	108.8	108.1	106.5	106.2	105.2	109.7	102.5
800.0	40	1,282	110.9	110.6	109.5	109.1	108.7	107.7	106.0	105.9	107.0	105.7	100.0
600.0	30	1,010	110.8	110.2	108.8	108.8	108.4	107.3	105.4	105.6	107.7	101.8	98.3
500.0	25	872	110.7	109.9	108.6	108.7	108.3	107.0	105.1	105.7	106.0	100.6	97.5
400.0	20	731	110.7	109.7	108.4	108.6	108.2	106.8	104.8	105.7	104.0	99.7	96.6

GENSET POWER WITH FAN	PERCENT LOAD	ENGINE POWER	1000 HZ	1250 HZ	1600 HZ	2000 HZ	2500 HZ	3150 HZ	4000 HZ	5000 HZ	6300 HZ	8000 HZ	10000 HZ
200.0	10	438	110.3	109.8	108.1	108.4	108.1	106.8	105.7	104.9	102.0	98.7	95.0

Emissions Data [Top](#)

Units Filter

Note(s)

EMISSIONS VALUES ARE TAILPIPE OUT WITH AFTERTREATMENT. VALUES SHOWN AS ZERO MAY BE GREATER THAN ZERO BUT WERE BELOW THE DETECTION LEVEL OF THE EQUIPMENT USED AT TIME OF MEASUREMENT.

CATERPILLAR EMISSIONS CERTIFIED ENGINES TESTED WITHIN EPA SPECIFIED TEST CONDITIONS, AND USING TITLE 40 CFR PART 1065 TEST PROTOCOL, MEET THE NEW SOURCE PERFORMANCE STANDARDS. POTENTIAL SITE VARIATION DATA ACCOUNT FOR PRODUCTION ENGINE AND SYSTEM VARIABILITY IN ADDITION TO MEASUREMENT VARIABILITY FOR TYPICAL FIELD TEST METHODS AS DESCRIBED IN DM1176. THIS DATA ASSUMES SITE CORRECTIONS FOR AMBIENT HUMIDITY TO 75 GRAINS, AND STANDARD CONDITIONS OF 25 C (77 F) AIR TO TURBO TEMPERATURE AND 152.4 M (500 FT) ALTITUDE. GUIDANCE ON HUMIDITY CORRECTION METHODS ARE AVAILABLE IN TITLE 40 CFR SECTION 1065.670. FOR APPLICATIONS WITH GEOGRAPHIC OR AMBIENT CONDITIONS BEYOND THESE PUBLISHED VALUES, CONSULT CATERPILLAR (APPLICATION SUPPORT CENTER) FOR ADDITIONAL VARIABILITY INFORMATION.

RATED SPEED POTENTIAL SITE VARIATION: 1800 RPM

GENSET POWER WITH FAN ENGINE POWER	EKW BHP	2,000.0 2,941	1,500.0 2,243	1,000.0 1,552	500.0 872	200.0 438
PERCENT LOAD	%	100	75	50	25	10
TOTAL NOX (AS NO2)	G/HR	1,788	1,240	740	438	537
TOTAL CO	G/HR	367	251	165	102	81
TOTAL HC	G/HR	95	108	102	81	99
PART MATTER	G/HR	69.3	68.2	61.4	55.3	24.3
TOTAL NOX (AS NO2)	(CORR 5% O2) MG/NM3	269.4	243.1	200.9	196.9	429.7
TOTAL CO	(CORR 5% O2) MG/NM3	58.0	51.6	46.6	47.3	65.3
TOTAL HC	(CORR 5% O2) MG/NM3	12.9	19.3	25.0	32.6	68.5
PART MATTER	(CORR 5% O2) MG/NM3	9.1	11.8	14.8	22.4	17.8
TOTAL NOX (AS NO2)	(CORR 5% O2) PPM	131	118	98	96	209
TOTAL CO	(CORR 5% O2) PPM	46	41	37	38	52
TOTAL HC	(CORR 5% O2) PPM	24	36	47	61	128
TOTAL NOX (AS NO2)	G/HP-HR	0.61	0.56	0.48	0.50	1.23
TOTAL CO	G/HP-HR	0.13	0.11	0.11	0.12	0.19
TOTAL HC	G/HP-HR	0.03	0.05	0.07	0.09	0.23
PART MATTER	G/HP-HR	0.02	0.03	0.04	0.06	0.06
TOTAL NOX (AS NO2)	LB/HR	3.94	2.73	1.63	0.96	1.18
TOTAL CO	LB/HR	0.81	0.55	0.36	0.22	0.18
TOTAL HC	LB/HR	0.21	0.24	0.22	0.18	0.22
PART MATTER	LB/HR	0.15	0.15	0.14	0.12	0.05

RATED SPEED NOMINAL DATA: 1800 RPM

GENSET POWER WITH FAN ENGINE POWER	EKW BHP	2,000.0 2,941	1,500.0 2,243	1,000.0 1,552	500.0 872	200.0 438
PERCENT LOAD	%	100	75	50	25	10
TOTAL NOX (AS NO2)	G/HR	1,117	775	462	274	336
TOTAL CO	G/HR	72	49	32	20	16
TOTAL HC	G/HR	21	24	23	18	22
TOTAL CO2	KG/HR	1,445	1,110	805	489	287
PART MATTER	G/HR	26.7	26.2	23.6	21.3	9.3
TOTAL NOX (AS NO2)	(CORR 5% O2) MG/NM3	168.4	151.9	125.6	123.1	268.6
TOTAL CO	(CORR 5% O2) MG/NM3	11.4	10.1	9.1	9.3	12.8
TOTAL HC	(CORR 5% O2) MG/NM3	2.9	4.3	5.6	7.3	15.2
PART MATTER	(CORR 5% O2) MG/NM3	3.5	4.5	5.7	8.6	6.9
TOTAL NOX (AS NO2)	(CORR 5% O2) PPM	82	74	61	60	131
TOTAL CO	(CORR 5% O2) PPM	9	8	7	7	10
TOTAL HC	(CORR 5% O2) PPM	5	8	10	14	28
FORMALDEHYDE	(CORR 15% O2) PPM	0.02	0.02	0.02	0.04	0.14
ACROLEIN	(CORR 15% O2) PPM	0.00	0.00	0.00	0.00	0.00
ACETALDEHYDE	(CORR 15% O2) PPM	0.00	0.00	0.00	0.00	0.01
METHANOL	(CORR 15% O2) PPM	0.00	0.00	0.00	0.00	0.01
TOTAL NOX (AS NO2)	G/HP-HR	0.38	0.35	0.30	0.32	0.77
TOTAL CO	G/HP-HR	0.02	0.02	0.02	0.02	0.04
TOTAL HC	G/HP-HR	0.01	0.01	0.01	0.02	0.05
PART MATTER	G/HP-HR	0.01	0.01	0.02	0.02	0.02
TOTAL NOX (AS NO2)	LB/HR	2.46	1.71	1.02	0.60	0.74
TOTAL CO	LB/HR	0.16	0.11	0.07	0.04	0.03
TOTAL HC	LB/HR	0.05	0.05	0.05	0.04	0.05
TOTAL CO2	LB/HR	3,185	2,447	1,776	1,077	632
PART MATTER	LB/HR	0.06	0.06	0.05	0.05	0.02
OXYGEN IN EXH	%	9.6	10.3	11.4	13.2	15.5
DRY SMOKE OPACITY	%	0.3	0.4	0.8	1.5	0.9
BOSCH SMOKE NUMBER		0.17	0.20	0.32	0.50	0.33

Regulatory Information [Top](#)

EPA TIER 4 FINAL		2015 - ----		
GASEOUS EMISSIONS DATA MEASUREMENTS PROVIDED TO THE EPA ARE CONSISTENT WITH THOSE DESCRIBED IN EPA 40 CFR PART 1039 SUBPART F AND ISO 8178 FOR MEASURING HC, CO, PM, AND NOX. THE "MAX LIMITS" SHOWN BELOW ARE WEIGHTED CYCLE AVERAGES AND ARE IN COMPLIANCE WITH THE NON-ROAD REGULATIONS BY PARTICIPATING IN THE AVERAGE, BANKING, AND TRADING PROGRAM.				
Locality	Agency	Regulation	Tier/Stage	Max Limits - G/BKW - HR
U.S. (INCL CALIF)	EPA	NON-ROAD GENSET	TIER 4 FINAL	CO: 3.5 NOx: 0.67 HC: 0.19 PM: 0.03

EPA TIER 4 INTERIM		2011 - 2014		
GASEOUS EMISSIONS DATA MEASUREMENTS PROVIDED TO THE EPA ARE CONSISTENT WITH THOSE DESCRIBED IN EPA 40 CFR PART 1039 SUBPART F AND ISO 8178 FOR MEASURING HC, CO, PM, AND NOX. THE "MAX LIMITS" SHOWN BELOW ARE WEIGHTED CYCLE AVERAGES AND ARE IN COMPLIANCE WITH THE NON-ROAD REGULATIONS.				
Locality	Agency	Regulation	Tier/Stage	Max Limits - G/BKW - HR
U.S. (INCL CALIF)	EPA	NON-ROAD GENSET	TIER 4 INTERIM	CO: 3.5 NOx: 0.67 HC: 0.4 PM: 0.10

EPA NON-EMERGENCY STATIONARY GENSET		2015 - ----		
GASEOUS EMISSIONS DATA MEASUREMENTS PROVIDED TO THE EPA ARE CONSISTENT WITH THOSE DESCRIBED IN EPA 40 CFR PART 60 SUBPART IIII AND ISO 8178 FOR MEASURING HC, CO, PM, AND NOX. THE "MAX LIMITS" SHOWN BELOW ARE WEIGHTED CYCLE AVERAGES AND ARE IN COMPLIANCE WITH THE NON-EMERGENCY STATIONARY REGULATIONS BY PARTICIPATING IN THE AVERAGE, BANKING, AND TRADING PROGRAM.				
Locality	Agency	Regulation	Tier/Stage	Max Limits - G/BKW - HR
U.S. (INCL CALIF)	EPA	STATIONARY	NON-EMERGENCY STATIONARY GENSET	CO: 3.5 NOx: 0.67 HC: 0.19 PM: 0.03

Altitude Derate Data [Top](#)

ALTITUDE CORRECTED POWER CAPABILITY (BHP)

AMBIENT OPERATING TEMP (F)	30	40	50	60	70	80	90	100	110	120	130	140	NORMAL
ALTITUDE (FT)													
0	2,944	2,944	2,944	2,944	2,944	2,944	2,944	2,944	2,944	2,944	2,944	2,944	2,944
1,000	2,944	2,944	2,944	2,944	2,944	2,944	2,944	2,944	2,944	2,944	2,944	2,944	2,944
2,000	2,944	2,944	2,944	2,944	2,944	2,944	2,944	2,944	2,944	2,944	2,944	2,944	2,944
3,000	2,944	2,944	2,944	2,944	2,944	2,944	2,944	2,944	2,944	2,944	2,944	2,944	2,944
4,000	2,944	2,944	2,944	2,944	2,944	2,944	2,944	2,944	2,944	2,944	2,944	2,944	2,944
5,000	2,944	2,944	2,944	2,944	2,944	2,944	2,944	2,944	2,944	2,944	2,944	2,944	2,944
6,000	2,944	2,944	2,944	2,944	2,944	2,944	2,944	2,944	2,944	2,935	2,885	2,837	2,944
7,000	2,944	2,944	2,944	2,944	2,944	2,944	2,944	2,926	2,874	2,825	2,777	2,730	2,944
8,000	2,944	2,944	2,944	2,944	2,944	2,919	2,866	2,815	2,766	2,718	2,672	2,627	2,944
9,000	2,944	2,944	2,944	2,916	2,861	2,808	2,757	2,708	2,660	2,614	2,570	2,527	2,944
10,000	2,944	2,916	2,859	2,804	2,751	2,700	2,651	2,604	2,558	2,514	2,471	2,430	2,853
11,000	2,861	2,804	2,749	2,696	2,645	2,596	2,549	2,503	2,459	2,417	2,376	2,336	2,762
12,000	2,750	2,695	2,642	2,591	2,542	2,495	2,449	2,406	2,363	2,323	2,283	2,245	2,673
13,000	2,642	2,589	2,539	2,490	2,443	2,397	2,354	2,312	2,271	2,232	2,194	2,157	2,587
14,000	2,539	2,488	2,439	2,392	2,347	2,303	2,262	2,221	2,182	2,144	2,108	2,073	2,504
15,000	2,439	2,390	2,343	2,298	2,255	2,213	2,173	2,134	2,096	2,060	2,025	1,991	2,423

Cross Reference [Top](#)

Test Spec	Setting	Engine Arrangement	Engineering Model

				Engineering Model Version	Start Effective Serial Number	End Effective Serial Number
3704798	LL6338	3709874	GS538	-	SCJ00001	SCJ00114
3704981	GG0624	3994250	GS718	-	DD700001	
3704981	GG0624	5075758	GS538	-	SCJ01000	
4581574	LL6763	5157722	PG238	-	LY600001	

Supplementary Data [Top](#)

Type	Classification	Performance Number
AFTERTREATMENT	SCR	DM8842

Performance Parameter Reference [Top](#)

Parameters Reference: DM9600 - 11

PERFORMANCE DEFINITIONS

PERFORMANCE DEFINITIONS DM9600

APPLICATION: Engine performance tolerance values below are representative of a typical production engine tested in a calibrated dynamometer test cell at SAE J1995 standard reference conditions. Caterpillar maintains ISO9001:2000 certified quality management systems for engine test Facilities to assure accurate calibration of test equipment. Engine test data is corrected in accordance with SAE J1995. Additional reference material SAE J1228, J1349, ISO 8665, 3046-1:2002E, 3046-3:1989, 1585, 2534, 2288, and 9249 may apply in part or are similar to SAE J1995. Special engine rating request (SERR) test data shall be noted.

PERFORMANCE PARAMETER TOLERANCE FACTORS: Power +/- 3% Torque +/- 3% Exhaust stack temperature +/- 8% Inlet airflow +/- 5% Intake manifold pressure-gage +/- 10% Exhaust flow +/- 6% Specific fuel consumption +/- 3% Fuel rate +/- 5% Specific DEF consumption +/- 3% DEF rate +/- 5% Heat rejection +/- 5% Heat rejection exhaust only +/- 10% Heat rejection CEM only +/- 10% Heat Rejection values based on using treated water. Torque is included for truck and industrial applications, do not use for Gen Set or steady state applications. On C7 - C18 engines, at speeds of 1100 RPM and under these values are provided for reference only, and may not meet the tolerance listed. These values do not apply to C280/3600. For these models, see the tolerances listed below.

C280/3600 HEAT REJECTION TOLERANCE FACTORS: Heat rejection +/- 10% Heat rejection to Atmosphere +/- 50% Heat rejection to Lube Oil +/- 20% Heat rejection to Aftercooler +/- 5%

TEST CELL TRANSDUCER TOLERANCE FACTORS: Torque +/- 0.5% Speed +/- 0.2% Fuel flow +/- 1.0% Temperature +/- 2.0 C degrees Intake manifold pressure +/- 0.1 kPa OBSERVED ENGINE PERFORMANCE IS CORRECTED TO SAE J1995 REFERENCE AIR AND FUEL CONDITIONS.

REFERENCE ATMOSPHERIC INLET AIR FOR 3500 ENGINES AND SMALLER SAE J1228 AUG2002 for marine engines, and J1995 JAN2014 for other engines, reference atmospheric pressure is 100 KPA (29.61 in hg), and standard temperature is 25deg C (77 deg F) at 30% relative humidity at the stated aftercooler water temp, or inlet manifold temp.
FOR 3600 ENGINES Engine rating obtained and presented in accordance with ISO 3046/1 and SAE J1995 JANJAN2014 reference atmospheric pressure is 100 KPA (29.61 in hg), and standard temperature is 25deg C (77 deg F) at 30% relative humidity and 150M altitude at the stated aftercooler water temperature.

MEASUREMENT LOCATION FOR INLET AIR TEMPERATURE Location for air temperature measurement air cleaner inlet at stabilized operating conditions.

REFERENCE EXHAUST STACK DIAMETER The Reference Exhaust Stack Diameter published with this dataset is only used for the calculation of Smoke Opacity values displayed in this dataset. This value does not necessarily represent the actual stack diameter of the engine due to the variety of exhaust stack adapter options available. Consult the price list, engine order or general dimension drawings for the actual stack diameter size ordered or options available.

REFERENCE FUEL DIESEL Reference fuel is #2 distillate diesel with a 35API gravity; A lower heating value is 42,780 KJ/KG (18,390 BTU/LB) when used at 29 deg C (84.2 deg F), where the density is 838.9 G/Liter (7.001 Lbs/Gal).

GAS Reference natural gas fuel has a lower heating value of 33.74 KJ/L (905 BTU/CU Ft). Low BTU ratings are based on 18.64 KJ/L (500 BTU/CU FT) lower heating value gas. Propane ratings are based on 87.56 KJ/L (2350 BTU/CU Ft) lower heating value gas.

ENGINE POWER (NET) IS THE CORRECTED FLYWHEEL POWER (GROSS) LESS EXTERNAL AUXILIARY LOAD Engine corrected gross output includes the power required to drive standard equipment; lube oil, scavange lube oil, fuel transfer, common rail fuel, separate circuit aftercooler and jacket water pumps. Engine net power available for the external (flywheel) load is calculated by subtracting the sum of auxiliary load from the corrected gross flywheel out put power. Typical auxiliary loads are radiator cooling fans, hydraulic pumps, air compressors and

battery charging alternators. For Tier 4 ratings additional Parasitic losses would also include Intake, and Exhaust Restrictions.

ALTITUDE CAPABILITY Altitude capability is the maximum altitude above sea level at standard temperature and standard pressure at which the engine could develop full rated output power on the current performance data set. Standard temperature values versus altitude could be seen on TM2001. When viewing the altitude capability chart the ambient temperature is the inlet air temp at the compressor inlet. Engines with ADEM MEUI and HEUI fuel systems operating at conditions above the defined altitude capability derate for atmospheric pressure and temperature conditions outside the values defined, see TM2001. Mechanical governor controlled unit injector engines require a setting change for operation at conditions above the altitude defined on the engine performance sheet. See your Caterpillar technical representative for non standard ratings.

REGULATIONS AND PRODUCT COMPLIANCE TMI Emissions information is presented at 'nominal' and 'Potential Site Variation' values for standard ratings. No tolerances are applied to the emissions data. These values are subject to change at any time. The controlling federal and local emission requirements need to be verified by your Caterpillar technical representative. Customer's may have special emission site requirements that need to be verified by the Caterpillar Product Group engineer.

EMISSIONS DEFINITIONS: Emissions : DM1176

EMISSION CYCLE DEFINITIONS

1. For constant-speed marine engines for ship main propulsion, including,diesel-electric drive, test cycle E2 shall be applied, for controllable-pitch propeller sets test cycle E2 shall be applied.
2. For propeller-law-operated main and propeller-law-operated auxiliary engines the test cycle E3 shall be applied.
3. For constant-speed auxiliary engines test cycle D2 shall be applied.
4. For variable-speed, variable-load auxiliary engines, not included above, test cycle C1 shall be applied.

HEAT REJECTION DEFINITIONS: Diesel Circuit Type and HHV Balance : DM9500

HIGH DISPLACEMENT (HD) DEFINITIONS: 3500: EM1500

RATING DEFINITIONS: Agriculture : TM6008

Fire Pump : TM6009
Generator Set : TM6035
Generator (Gas) : TM6041
Industrial Diesel : TM6010
Industrial (Gas) : TM6040
Irrigation : TM5749
Locomotive : TM6037
Marine Auxiliary : TM6036
Marine Prop (Except 3600) : TM5747
Marine Prop (3600 only) : TM5748
MSHA : TM6042
Oil Field (Petroleum) : TM6011
Off-Highway Truck : TM6039
On-Highway Truck : TM6038

SOUND DEFINITIONS: Sound Power : DM8702
Sound Pressure : TM7080

Date Released : 11/29/18

B. PROCESS FLOW DIAGRAMS WITH EMISSION POINTS

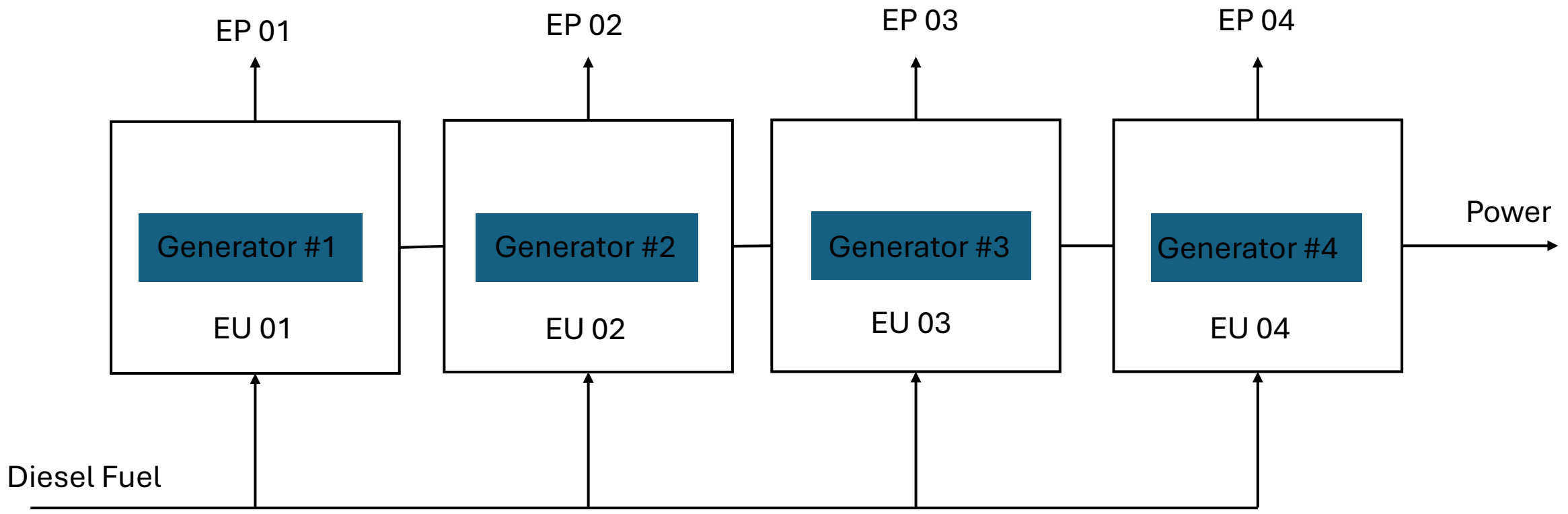

Generators #1- #4: Four new 2000 kW generators

C. GENERAL LOCATION MAP

Site Location

Installation of four (4) new diesel emergency generators rated at 2,000 ekW.

4 Generators

Perry Point VA Medical Center - VA Maryland Health Care System

D. EMISSIONS CALCULATIONS

Source Description and Location	MDE Registration Number	Source Fuel Type	Maximum Heat Input, EACH		Annual Operation, EACH		Pollutant	Emission Factors				Potential Emission Estimate, EACH		Potential Emission Estimate, ALL	
			rate	unit	rate	unit		rate	unit	source	GWP ^b	lb/hr	tons/yr	lb/hr	tons/yr
One (1) Existing Non-Emergency Generator (EG-17H, 450 kW or 685 bhp)	9-0213	No. 2 Fuel Oil	685.00	bhp	50	hr	VOC	6.42E-04	lb/hp-hr	3	-	0.44	0.01	0.44	0.01
			685.00	bhp	50	hr	NO _x	2.40E-02	lb/hp-hr	3	-	16.44	0.41	16.44	0.41
			685.00	bhp	50	hr	CO	5.50E-03	lb/hp-hr	3	-	3.77	0.09	3.77	0.09
			685.00	bhp	50	hr	PM ₁₀ /PM _{2.5}	7.00E-04	lb/hp-hr	3	-	0.48	0.01	0.48	0.01
			685.00	bhp	50	hr	SO ₂	1.21E-05	lb/hp-hr	3	-	0.01	0.00	0.01	0.00
			6.79	MMBtu/hr	50	hr	CO ₂	163.05	lb/MMBtu	1	1	1,107.14	27.68	1,107.14	27.68
			6.79	MMBtu/hr	50	hr	N ₂ O	1.32E-03	lb/MMBtu	1	298	8.96E-03	2.24E-04	0.01	0.00
			6.79	MMBtu/hr	50	hr	CH ₄	6.61E-03	lb/MMBtu	1	25	3.14E-04	7.85E-06	0.00	0.00
-	-	-	-	CO ₂ e	-	-	2	-	1,109.82	27.75	1,109.82	27.75			
One (1) Existing Non-Emergency Generator (EG-324, 75 kW or 155 bhp)	9-0234	No. 2 Fuel Oil	155.00	bhp	50	hr	VOC	2.51E-03	lb/hp-hr	4	-	0.39	0.01	0.39	0.01
			155.00	bhp	50	hr	NO _x	3.10E-02	lb/hp-hr	4	-	4.81	0.12	4.81	0.12
			155.00	bhp	50	hr	CO	6.68E-03	lb/hp-hr	4	-	1.04	0.03	1.04	0.03
			155.00	bhp	50	hr	PM ₁₀ /PM _{2.5}	2.20E-03	lb/hp-hr	4	-	0.34	0.01	0.34	0.01
			155.00	bhp	50	hr	SO ₂	2.05E-03	lb/hp-hr	4	-	0.32	0.01	0.32	0.01
			1.09	MMBtu/hr	50	hr	CO ₂	163.05	lb/MMBtu	1	1	176.91	4.42	176.91	4.42
			1.09	MMBtu/hr	50	hr	N ₂ O	1.32E-03	lb/MMBtu	1	298	1.43E-03	3.58E-05	0.00	0.00
			1.09	MMBtu/hr	50	hr	CH ₄	6.61E-03	lb/MMBtu	1	25	5.02E-05	1.26E-06	0.00	0.00
-	-	-	-	CO ₂ e	-	-	2	-	177.34	4.43	177.34	4.43			
One (1) Existing Non-Emergency Generator (EG-329, 100 kW or 227 bhp)	9-0235	No. 2 Fuel Oil	227.00	bhp	50	hr	VOC	2.51E-03	lb/hp-hr	4	-	0.57	0.01	0.57	0.01
			227.00	bhp	50	hr	NO _x	3.10E-02	lb/hp-hr	4	-	7.04	0.18	7.04	0.18
			227.00	bhp	50	hr	CO	6.68E-03	lb/hp-hr	4	-	1.52	0.04	1.52	0.04
			227.00	bhp	50	hr	PM ₁₀ /PM _{2.5}	2.20E-03	lb/hp-hr	4	-	0.50	0.01	0.50	0.01
			227.00	bhp	50	hr	SO ₂	2.05E-03	lb/hp-hr	4	-	0.47	0.01	0.47	0.01
			1.59	MMBtu/hr	50	hr	CO ₂	163.05	lb/MMBtu	1	1	259.09	6.48	259.09	6.48
			1.59	MMBtu/hr	50	hr	N ₂ O	1.32E-03	lb/MMBtu	1	298	2.10E-03	5.24E-05	0.00	0.00
			1.59	MMBtu/hr	50	hr	CH ₄	6.61E-03	lb/MMBtu	1	25	7.35E-05	1.84E-06	0.00	0.00
-	-	-	-	CO ₂ e	-	-	2	-	259.72	6.49	259.72	6.49			
One (1) Existing Non-Emergency Generator (EG-19H, 230 kW or 380 bhp)	9-0236	No. 2 Fuel Oil	380.00	bhp	50	hr	VOC	2.51E-03	lb/hp-hr	4	-	0.96	0.02	0.96	0.02
			380.00	bhp	50	hr	NO _x	3.10E-02	lb/hp-hr	4	-	11.78	0.29	11.78	0.29
			380.00	bhp	50	hr	CO	6.68E-03	lb/hp-hr	4	-	2.54	0.06	2.54	0.06
			380.00	bhp	50	hr	PM ₁₀ /PM _{2.5}	2.20E-03	lb/hp-hr	4	-	0.84	0.02	0.84	0.02
			380.00	bhp	50	hr	SO ₂	2.05E-03	lb/hp-hr	4	-	0.78	0.02	0.78	0.02
			2.66	MMBtu/hr	50	hr	CO ₂	163.05	lb/MMBtu	1	1	433.72	10.84	433.72	10.84
			2.66	MMBtu/hr	50	hr	N ₂ O	1.32E-03	lb/MMBtu	1	298	3.51E-03	8.78E-05	0.00	0.00
			2.66	MMBtu/hr	50	hr	CH ₄	6.61E-03	lb/MMBtu	1	25	1.23E-04	3.08E-06	0.00	0.00
-	-	-	-	CO ₂ e	-	-	2	-	434.77	10.87	434.77	10.87			
Four (4) Proposed Non-Emergency Generators (2,000 kW or 2941 bhp each)	TBD	No. 2 Fuel Oil	2941.00	bhp	250	hr	VOC	1.47E+00	lb/hr	4	-	1.47	0.18	5.88	0.74
			2941.00	bhp	250	hr	NO _x	1.29E+01	lb/hr	4	-	12.94	1.62	51.76	6.47
			2941.00	bhp	250	hr	CO	1.62E+01	lb/hr	4	-	16.18	2.02	64.72	8.09
			2941.00	bhp	250	hr	PM ₁₀ /PM _{2.5}	2.90E-01	lb/hr	4	-	0.29	0.04	1.16	0.15
			2941.00	bhp	250	hr	SO ₂	1.21E-05	lb/hp-hr	4	-	0.04	0.0045	0.14	0.02
			19.52	MMBtu/hr	250	hr	CO ₂	163.05	lb/MMBtu	1	1	3.18E+03	397.77	12,728.65	1,591.08
			19.52	MMBtu/hr	250	hr	N ₂ O	1.32E-03	lb/MMBtu	1	298	2.58E-02	0.00	0.10	0.01
			19.52	MMBtu/hr	250	hr	CH ₄	6.61E-03	lb/MMBtu	1	25	1.29E-01	1.61E-02	0.52	0.06
-	-	-	-	CO ₂ e	-	-	2	-	3,193.06	399.13	12,772.25	1,596.53			

Source Description and Location	MDE Registration Number	Source Fuel Type	Maximum Heat Input, EACH		Annual Operation, EACH		Pollutant	Emission Factors				Potential Emission Estimate, EACH		Potential Emission Estimate, ALL	
					rate	unit		rate	unit	source	GWP ^b	lb/hr	tons/yr	lb/hr	tons/yr
Three (3) Existing Upgraded and Permitted Steam Boilers, (46 MMBtu/hr each) ^d	5-0070 5-0072 5-0073	No. 2 Fuel Oil (secondary fuel)	46.00	MMBtu/hr	15771	gal/year	VOC	2.43E-03	lb/MMBtu	5	-	0.11	0.01	0.34	0.02
			46.00	MMBtu/hr	15771	gal/year	NO _x ^c	9.29E-02	lb/MMBtu	5	-	4.27	0.31	12.81	0.92
			46.00	MMBtu/hr	15771	gal/year	CO	3.57E-02	lb/MMBtu	5	-	1.64	0.12	4.93	0.35
			46.00	MMBtu/hr	15771	gal/year	PM ^a	2.36E-02	lb/MMBtu	5	-	1.08	0.08	3.25	0.23
			46.00	MMBtu/hr	15771	gal/year	SO ₂	1.52E-03	lb/MMBtu	5	-	0.07	0.01	0.21	0.02
			46.00	MMBtu/hr	15771	gal/year	CO ₂	163.05	lb/MMBtu	1	1	7,500.48	540.03	22,501.45	1,620.10
			46.00	MMBtu/hr	15771	gal/year	N ₂ O	1.32E-03	lb/MMBtu	1	298	0.06	0.00	0.18	0.01
	46.00	MMBtu/hr	15771	gal/year	CH ₄	6.61E-03	lb/MMBtu	1	25	0.30	0.02	0.91	0.07		
	-	-	-	-	CO ₂ e	-	-	2	-	7,526.18	541.88	22,578.54	1,625.65		
	Natural Gas (primary fuel)	46.00	MMBtu/hr	161000	MMBtu/yr	VOC	5.39E-03	lb/MMBtu	6	-	0.25	0.43	0.74	1.30	
		46.00	MMBtu/hr	161000	MMBtu/yr	NO _x	3.14E-02	lb/MMBtu	6	-	1.44	2.53	4.33	7.58	
		46.00	MMBtu/hr	161000	MMBtu/yr	CO	8.24E-02	lb/MMBtu	6	-	3.79	6.63	11.36	19.89	
		46.00	MMBtu/hr	161000	MMBtu/yr	PM ^a	7.45E-03	lb/MMBtu	6	-	0.34	0.60	1.03	1.80	
		46.00	MMBtu/hr	161000	MMBtu/yr	SO ₂	5.88E-04	lb/MMBtu	6	-	0.03	0.05	0.08	0.14	
46.00		MMBtu/hr	161000	MMBtu/yr	CO ₂	116.98	lb/MMBtu	1	1	5,381.08	9,416.89	16,143.24	28,250.67		
46.00		MMBtu/hr	161000	MMBtu/yr	N ₂ O	2.21E-04	lb/MMBtu	1	298	0.01	0.02	0.03	0.05		
46.00	MMBtu/hr	161000	MMBtu/yr	CH ₄	2.21E-03	lb/MMBtu	1	25	0.10	0.18	0.30	0.53			
-	-	-	-	CO ₂ e	-	-	2	-	5,386.64	9,426.62	16,159.92	28,279.85			
One (1) Replacement Boiler, B&W FM 10-52 (38.48 MMBtu/hr for NG, 37 MMBtu/hr for Oil) ^d	5-0161	No. 2 Fuel Oil (secondary fuel)	37.00	MMBtu/hr	26429	gal/year	VOC	2.43E-03	lb/MMBtu	5	-	0.09	0.00	0.09	0.00
			37.00	MMBtu/hr	26429	gal/year	NO _x	1.09E-01	lb/MMBtu	5	-	4.03	0.20	4.03	0.20
			37.00	MMBtu/hr	26429	gal/year	CO	1.48E-01	lb/MMBtu	5	-	5.48	0.27	5.48	0.27
			37.00	MMBtu/hr	26429	gal/year	PM ^a	2.36E-02	lb/MMBtu	5	-	0.87	0.04	0.87	0.04
			37.00	MMBtu/hr	26429	gal/year	SO ₂	1.52E-03	lb/MMBtu	5	-	0.06	0.00	0.06	0.00
			37.00	MMBtu/hr	26429	gal/year	CO ₂	163.05	lb/MMBtu	1	1	6,033.00	301.65	6,033.00	301.65
			37.00	MMBtu/hr	26429	gal/year	N ₂ O	1.32E-03	lb/MMBtu	1	298	0.05	0.00	0.05	0.00
	37.00	MMBtu/hr	26429	gal/year	CH ₄	6.61E-03	lb/MMBtu	1	25	0.24	0.01	0.24	0.01		
	-	-	-	-	CO ₂ e	-	-	2	-	6,053.67	302.68	6,053.67	302.68		
	Natural Gas (primary fuel)	38.48	MMBtu/hr	211640	MMBtu/yr	VOC	5.39E-03	lb/MMBtu	6	-	0.21	0.57	0.21	0.57	
		38.48	MMBtu/hr	211640	MMBtu/yr	NO _x	3.60E-02	lb/MMBtu	6	-	1.39	3.81	1.39	3.81	
		38.48	MMBtu/hr	211640	MMBtu/yr	CO	1.48E-01	lb/MMBtu	6	-	5.70	15.66	5.70	15.66	
		38.48	MMBtu/hr	211640	MMBtu/yr	PM ^a	7.45E-03	lb/MMBtu	6	-	0.29	0.79	0.29	0.79	
		38.48	MMBtu/hr	211640	MMBtu/yr	SO ₂	5.88E-04	lb/MMBtu	6	-	0.02	0.06	0.02	0.06	
38.48		MMBtu/hr	211640	MMBtu/yr	CO ₂	116.98	lb/MMBtu	1	1	4,501.39	12,378.82	4,501.39	12,378.82		
38.48		MMBtu/hr	211640	MMBtu/yr	N ₂ O	2.21E-04	lb/MMBtu	1	298	0.01	0.02	0.01	0.02		
38.48	MMBtu/hr	211640	MMBtu/yr	CH ₄	2.21E-03	lb/MMBtu	1	25	0.08	0.23	0.08	0.23			
-	-	-	-	CO ₂ e	-	-	2	-	4,506.04	12,391.61	4,506.04	12,391.61			

Total

	lb/hr	ton/yr
VOC	8.66	2.70
NO _x	114.38	19.98
CO	101.04	44.49
PM	8.76	3.06
SO ₂	2.08	0.28
CO ₂	63,884.59	44,191.75
N ₂ O	0.39	0.11
CH ₄	2.06	0.91
CO ₂ e	64,052.07	44,245.87

Emission Factors:

- 40 CFR 98, Subpart C, Table 1 and Table 2
- CO₂e Emissions = (CO₂ Emissions * CO₂ GWP) + (CH₄ Emissions * CH₄ GWP) + (N₂O Emissions * N₂O GWP)
- Large Stationary Engines Diesel Fuel Emission Factors from AP-42 Chapter 3.4, Tables 3.4-1 through 3.4-5
- Diesel Industrial Engines Emission Factors from AP-42 Chapter 3.3, Tables 3.3-1
- External Combustion No.2 Fuel Oil Factors from AP-42 Chapter 1.3, Tables 1.3-1 through 1.3-12
- Natural Gas Emission Factors from AP-42 Chapter 1.4, Tables 1.4-1, 1.4-2 for small boilers (<100 MMBtu/hr) and controlled with low-NO_x burner and FGR

Notes:

- PM Total = PM, Filterable + PM, Condensable (All PM is assumed to be less than 1 micronmeter in diameter; PM=PM10=PM2.5=PM1)
- GWP - Global Warming Potential
- Low NO_x burners reduction potential runs from 20 to 50% per AP-42 Chapter 1 Table 1.3-14. Reduction of 35% used on this calculation.

Conversion Factors:

To convert to an energy basis (lb/MMBtu), divide by a heating value of 140 MMBtu/10³gal for No. 2 and distillate fuel oil.

**Air Emission Analysis
Criteria Pollutants
VAMC Perry Point**

Emissions Summary (TPY)

Pollutant	PTE Estimate					Total PTE	Major Source Thresholds for Maryland*
	3 Boilers	4 Engines	1 Boiler	Subtotal	4 Engines		
VOC	1.31	0.06	0.58	<i>1.94</i>	0.74	2.68	25 ^a
NO _x	7.88	1.00	4.01	<i>12.90</i>	6.47	19.37	25 ^a
CO	20.01	0.22	15.94	<i>36.16</i>	8.09	44.25	100
PM	2.03	0.05	0.83	<i>2.92</i>	0.15	3.06	100
SO ₂	0.16	0.04	0.07	<i>0.26</i>	0.02	0.28	100
CO ₂	29,870.77	49.42	12,680.47	<i>42,601</i>	1,591.08	44,191.75	-
N ₂ O	0.07	0.00	0.03	<i>0.09</i>	0.01	0.11	-
CH ₄	0.54	0.00	0.25	<i>0.79</i>	0.06	0.85	-
CO ₂ e	29,905.51	49.54	12,694.29	<i>42,649</i>	1,596.53	44,245.87	-
HAP	0.46	0.00	0.20	<i>0.66</i>	0.01	0.67	10 single HAP or 25 any combination of HAPs

Notes:

^a Specific thresholds for several counties in Maryland including Cecil County

Perry Point VAMC
Actual Emission Calculations
Boiler HAPs

Boilers

Natural gas consumption =	161.0000	10 ⁶ scf/12-month
No. 2 fuel oil consumption =	15.7700	10 ³ gallon/12-month

HAPs	NG Combustion Emission Factor ¹	NG Combustion HAP Emissions		No. 2 FO Combustion Emission Factor ²	No. 2 Fuel Oil HAP Emissions		PTE	
	lb/10 ⁶ scf	lb/hr	tpy	lb/10 ³ gal	lb/hr	tpy	lb/hr	tpy
1,1,1-Trichloroethane	-			2.36E-04	7.75E-05	1.86E-06	7.75E-05	1.86E-06
2-Methylnaphthaleneb	2.40E-05	1.10E-06	1.93E-06	-			1.10E-06	1.93E-06
3-Methylchloranthrene	1.80E-06	8.28E-08	1.45E-07	-			8.28E-08	1.45E-07
7,12-Dimethylbenz(a)anthracene	1.60E-05	7.36E-07	1.29E-06	-			7.36E-07	1.29E-06
Acenaphthene	1.80E-06	8.28E-08	1.45E-07	-			8.28E-08	1.45E-07
Acenaphthylene	1.80E-06	8.28E-08	1.45E-07	-			8.28E-08	1.45E-07
Anthracene	2.40E-06	1.10E-07	1.93E-07	-			1.10E-07	1.93E-07
Arsenic	2.00E-04	9.20E-06	1.61E-05	-			9.20E-06	1.61E-05
Benzene	2.10E-03	9.66E-05	1.69E-04	2.14E-04	7.03E-05	1.69E-06	1.67E-04	1.71E-04
Benz(a)anthracene	1.80E-06	8.28E-08	1.45E-07	-			8.28E-08	1.45E-07
Benzo(a)pyrene	1.20E-06	5.52E-08	9.66E-08	-			5.52E-08	9.66E-08
Benzo(b)fluoranthene	1.80E-06	8.28E-08	1.45E-07	-			8.28E-08	1.45E-07
Benzo(g,h,i)perylene	1.20E-06	5.52E-08	9.66E-08	-			5.52E-08	9.66E-08
Benzo(k)fluoranthene	1.80E-06	8.28E-08	1.45E-07	-			8.28E-08	1.45E-07
Beryllium	1.20E-05	5.52E-07	9.66E-07	-			5.52E-07	9.66E-07
Cadmium	1.10E-03	5.06E-05	8.86E-05	-			5.06E-05	8.86E-05
Chrysene	1.80E-06	8.28E-08	1.45E-07	-			8.28E-08	1.45E-07
Chromium	1.40E-03	6.44E-05	1.13E-04	-			6.44E-05	1.13E-04
Cobalt	8.40E-05	3.86E-06	6.76E-06	-			3.86E-06	6.76E-06
Dibenzo(a,h)anthracene	1.20E-06	5.52E-08	9.66E-08	-			5.52E-08	9.66E-08
Dichlorobenzene	1.20E-03	5.52E-05	9.66E-05	-			5.52E-05	9.66E-05
Ethylbenzene	-			6.36E-05	2.09E-05	5.01E-07	2.09E-05	5.01E-07
Fluoranthene	3.00E-06	1.38E-07	2.42E-07	-			1.38E-07	2.42E-07
Fluorene	2.80E-06	1.29E-07	2.25E-07	-			1.29E-07	2.25E-07
Formaldehyde	7.50E-02	3.45E-03	6.04E-03	3.30E-02	1.08E-02	2.60E-04	1.43E-02	6.30E-03
Hexane	1.80E+00	8.28E-02	1.45E-01	-			8.28E-02	1.45E-01
Indeno(1,2,3-cd)pyrene	1.80E-06	8.28E-08	1.45E-07	-			8.28E-08	1.45E-07
Manganese	3.80E-04	1.75E-05	3.06E-05	-			1.75E-05	3.06E-05
Mercury	2.60E-04	1.20E-05	2.09E-05	-			1.20E-05	2.09E-05
Naphthalene	6.10E-04	2.81E-05	4.91E-05	1.13E-03	3.71E-04	8.91E-06	3.99E-04	5.80E-05
Nickel	2.10E-03	9.66E-05	1.69E-04	-			9.66E-05	1.69E-04
Phenanathrene	1.70E-05	7.82E-07	1.37E-06	-			7.82E-07	1.37E-06
Pyrene	5.00E-06	2.30E-07	4.03E-07	-			2.30E-07	4.03E-07
Selenium	2.40E-05	1.10E-06	1.93E-06	-			1.10E-06	1.93E-06
Toluene	3.40E-03	1.56E-04	2.74E-04	6.20E-03	2.04E-03	4.89E-05	2.19E-03	3.23E-04
Xylene	-			1.09E-04	3.58E-05	8.59E-07	3.58E-05	8.59E-07
Total		0.09	0.15		0.01	0.00	0.10	0.15

¹ AP-42 Chapter 1.4 Emission Factors for Speciated Organic Compounds from Natural Gas Combustion (Tables 1.4-3 & 4)

² AP-42 Chapter 1.3 Emission Factors for Speciated Organic Compounds from Fuel Oil Combustion (Tables 1.3-9)

Perry Point VAMC
Actual Emission Calculations
Boiler HAPs

Boilers

Natural gas consumption =	211.6000	10 ⁶ scf/12-month
No. 2 fuel oil consumption =	26.4200	10 ³ gallon/12-month

HAPs	NG Combustion Emission Factor ¹	NG Combustion HAP Emissions		No 2 FO Combustion Emission Factor ²	No. 2 Fuel Oil HAP Emissions		PTE	
	lb/10 ⁶ scf	lb/hr	tpy	lb/10 ³ gal	lb/hr	tpy	lb/hr	tpy
1,1,1-Trichloroethane	-			2.36E-04	6.24E-05	3.12E-06	6.24E-05	3.12E-06
2-Methylnaphthaleneb	2.40E-05	9.23E-07	2.54E-06	-			9.23E-07	2.54E-06
3-Methylchloranthrene	1.80E-06	6.93E-08	1.90E-07	-			6.93E-08	1.90E-07
7,12-Dimethylbenz(a)anthracene	1.60E-05	6.16E-07	1.69E-06	-			6.16E-07	1.69E-06
Acenaphthene	1.80E-06	6.93E-08	1.90E-07	-			6.93E-08	1.90E-07
Acenaphthylene	1.80E-06	6.93E-08	1.90E-07	-			6.93E-08	1.90E-07
Anthracene	2.40E-06	9.23E-08	2.54E-07	-			9.23E-08	2.54E-07
Arsenic	2.00E-04	7.69E-06	2.12E-05	-			7.69E-06	2.12E-05
Benzene	2.10E-03	8.08E-05	2.22E-04	2.14E-04	5.65E-05	2.83E-06	8.08E-05	2.22E-04
Benz(a)anthracene	1.80E-06	6.93E-08	1.90E-07	-			6.93E-08	1.90E-07
Benzo(a)pyrene	1.20E-06	4.62E-08	1.27E-07	-			4.62E-08	1.27E-07
Benzo(b)fluoranthene	1.80E-06	6.93E-08	1.90E-07	-			6.93E-08	1.90E-07
Benzo(g,h,i)perylene	1.20E-06	4.62E-08	1.27E-07	-			4.62E-08	1.27E-07
Benzo(k)fluoranthene	1.80E-06	6.93E-08	1.90E-07	-			6.93E-08	1.90E-07
Beryllium	1.20E-05	4.62E-07	1.27E-06	-			4.62E-07	1.27E-06
Cadmium	1.10E-03	4.23E-05	1.16E-04	-			4.23E-05	1.16E-04
Chrysene	1.80E-06	6.93E-08	1.90E-07	-			6.93E-08	1.90E-07
Chromium	1.40E-03	5.39E-05	1.48E-04	-			5.39E-05	1.48E-04
Cobalt	8.40E-05	3.23E-06	8.89E-06	-			3.23E-06	8.89E-06
Dibenzo(a,h)anthracene	1.20E-06	4.62E-08	1.27E-07	-			4.62E-08	1.27E-07
Dichlorobenzene	1.20E-03	4.62E-05	1.27E-04	-			4.62E-05	1.27E-04
Ethylbenzene	-			6.36E-05	1.68E-05	8.40E-07	0.00E+00	0.00E+00
Fluoranthene	3.00E-06	1.15E-07	3.17E-07	-			1.15E-07	3.17E-07
Fluorene	2.80E-06	1.08E-07	2.96E-07	-			1.08E-07	2.96E-07
Formaldehyde	7.50E-02	2.89E-03	7.94E-03	3.30E-02	8.72E-03	4.36E-04	2.89E-03	7.94E-03
Hexane	1.80E+00	6.93E-02	1.90E-01	-			6.93E-02	1.90E-01
Indeno(1,2,3-cd)pyrene	1.80E-06	6.93E-08	1.90E-07	-			6.93E-08	1.90E-07
Manganese	3.80E-04	1.46E-05	4.02E-05	-			1.46E-05	4.02E-05
Mercury	2.60E-04	1.00E-05	2.75E-05	-			1.00E-05	2.75E-05
Naphthalene	6.10E-04	2.35E-05	6.45E-05	1.13E-03	2.99E-04	1.49E-05	2.35E-05	6.45E-05
Nickel	2.10E-03	8.08E-05	2.22E-04	-			8.08E-05	2.22E-04
Phenanthrene	1.70E-05	6.54E-07	1.80E-06	-			6.54E-07	1.80E-06
Pyrene	5.00E-06	1.92E-07	5.29E-07	-			1.92E-07	5.29E-07
Selenium	2.40E-05	9.23E-07	2.54E-06	-			9.23E-07	2.54E-06
Toluene	3.40E-03	1.31E-04	3.60E-04	6.20E-03	1.64E-03	8.19E-05	1.31E-04	3.60E-04
Xylene	-			1.09E-04	2.88E-05	1.44E-06	0.00E+00	0.00E+00
Total		0.07	0.20		0.01	0.00	0.07	0.20

¹ AP-42 Chapter 1.4 Emission Factors for Speciated Organic Compounds from Natural Gas Combustion (Tables 1.4-3 & 4)

² AP-42 Chapter 1.3 Emission Factors for Speciated Organic Compounds from Fuel Oil Combustion (Tables 1.3-9)

**Perry Point VAMC
Emergency Generator HAPs**

Generators HAPs

Engine Heat Input, MMBtu/hr	6.79	Operating Hours	50.0	hr/yr
-----------------------------	------	-----------------	------	-------

HAPs	Emission Factor ¹	HAP Emissions	
	lb/MMBtu	lb/hr	tpy
Naphthalene	1.30E-04	8.83E-04	2.21E-05
Benzene	7.76E-04	5.27E-03	1.32E-04
Toluene	2.81E-04	1.91E-03	4.77E-05
Xylenes	1.93E-04	1.31E-03	3.28E-05
Propylene	2.79E-03	1.89E-02	4.74E-04
Formaldehyde	7.89E-05	5.36E-04	1.34E-05
Acetaldehyde	2.52E-05	1.71E-04	4.28E-06
Acrolein	7.88E-06	5.35E-05	1.34E-06
Total	-	0.029	0.001

¹ AP-42 Chapter 3.4 Large Stationary Diesel And All Stationary Dual-fuel Engines (Tables 3.4-3 & 4)

Engine Heat Input, MMBtu/hr	1.09	Operating Hours	50.0	hr/yr
-----------------------------	------	-----------------	------	-------

HAPs	Emission Factor ¹	HAP Emissions	
	lb/MMBtu	lb/hr	tpy
Naphthalene	1.30E-04	1.42E-04	3.54E-06
Benzene	7.76E-04	8.46E-04	2.11E-05
Toluene	2.81E-04	3.06E-04	7.66E-06
Xylenes	1.93E-04	2.10E-04	5.26E-06
Propylene	2.79E-03	3.04E-03	7.60E-05
Formaldehyde	7.89E-05	8.60E-05	2.15E-06
Acetaldehyde	2.52E-05	2.75E-05	6.87E-07
Acrolein	7.88E-06	8.59E-06	2.15E-07
Total	-	0.005	0.000

¹ AP-42 Chapter 3.4 Large Stationary Diesel And All Stationary Dual-fuel Engines (Tables 3.4-3 & 4)

Engine Heat Input, MMBtu/hr	1.59	Operating Hours	50.0	hr/yr
-----------------------------	------	-----------------	------	-------

HAPs	Emission Factor ¹	HAP Emissions	
	lb/MMBtu	lb/hr	tpy
Naphthalene	1.30E-04	2.07E-04	5.17E-06
Benzene	7.76E-04	1.23E-03	3.08E-05
Toluene	2.81E-04	4.47E-04	1.12E-05
Xylenes	1.93E-04	3.07E-04	7.67E-06
Propylene	2.79E-03	4.44E-03	1.11E-04
Formaldehyde	7.89E-05	1.25E-04	3.14E-06
Acetaldehyde	2.52E-05	4.01E-05	1.00E-06
Acrolein	7.88E-06	1.25E-05	3.13E-07
Total	-	0.007	0.000

**Perry Point VAMC
Emergency Generator HAPs**

¹ AP-42 Chapter 3.4 Large Stationary Diesel And All Stationary Dual-fuel Engines (Tables 3.4-3 & 4)

Engine Heat Input, MMBtu/hr	2.66	Operating Hours	50.0	hr/yr
-----------------------------	------	-----------------	------	-------

HAPs	Emission Factor ¹	HAP Emissions	
	lb/MMBtu	lb/hr	tpy
Naphthalene	1.30E-04	3.46E-04	8.65E-06
Benzene	7.76E-04	2.06E-03	5.16E-05
Toluene	2.81E-04	7.47E-04	1.87E-05
Xylenes	1.93E-04	5.13E-04	1.28E-05
Propylene	2.79E-03	7.42E-03	1.86E-04
Formaldehyde	7.89E-05	2.10E-04	5.25E-06
Acetaldehyde	2.52E-05	6.70E-05	1.68E-06
Acrolein	7.88E-06	2.10E-05	5.24E-07
Total	-	0.011	0.000

¹ AP-42 Chapter 3.4 Large Stationary Diesel And All Stationary Dual-fuel Engines (Tables 3.4-3 & 4)

**Perry Point VAMC
Actual Emission Calculations
Emergency Generator HAPs**

Generators HAPs

Engine Heat Input, MMBtu/hr	19.52	Operating Hours	250.0	hr/yr
-----------------------------	-------	-----------------	-------	-------

HAPs	Emission Factor ¹	HAP Emissions		HAP Emissions (All 4 Units)	
	lb/MMBtu	lb/hr	tpy	lb/hr	tpy
Naphthalene	1.30E-04	2.54E-03	3.17E-04	1.01E-02	1.27E-03
Benzene	7.76E-04	1.51E-02	1.89E-03	6.06E-02	7.57E-03
Toluene	2.81E-04	5.48E-03	6.85E-04	2.19E-02	2.74E-03
Xylenes	1.93E-04	3.77E-03	4.71E-04	1.51E-02	1.88E-03
Propylene	2.79E-03	5.44E-02	6.81E-03	2.18E-01	2.72E-02
Formaldehyde	7.89E-05	1.54E-03	1.92E-04	6.16E-03	7.70E-04
Acetaldehyde	2.52E-05	4.92E-04	6.15E-05	1.97E-03	2.46E-04
Acrolein	7.88E-06	1.54E-04	1.92E-05	6.15E-04	7.69E-05
Total	-	0.084	0.010	0.334	0.042

¹ AP-42 Chapter 3.4 Large Stationary Diesel And All Stationary Dual-fuel Engines (Tables 3.4-3 & 4)

E. EPA TIER 4 EXHAUST EMISSION COMPLIANCE STATEMENT



UNITED STATES ENVIRONMENTAL PROTECTION AGENCY
2019 MODEL YEAR
CERTIFICATE OF CONFORMITY
WITH THE CLEAN AIR ACT

OFFICE OF TRANSPORTATION
AND AIR QUALITY
ANN ARBOR, MICHIGAN 48105

Certificate Issued To: Caterpillar Inc.
(U.S. Manufacturer or Importer)
Certificate Number: KCPXL78.1NSF-015

Effective Date:
07/24/2018
Expiration Date:
12/31/2019

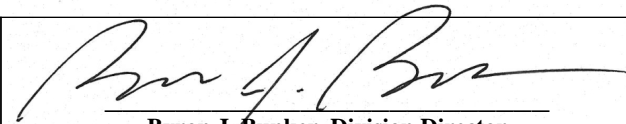
Byron J. Bunker, Division Director
Compliance Division

Issue Date:
07/24/2018
Revision Date:
N/A

Model Year: 2019
Manufacturer Type: Original Engine Manufacturer
Engine Family: KCPXL78.1NSF

Mobile/Stationary Indicator: Both
Emissions Power Category: kW>900
Fuel Type: Diesel
After Treatment Devices: Diesel Oxidation Catalyst, Ammonia Slip Catalyst, Selective Catalytic Reduction
Non-after Treatment Devices: Electronic Control, Engine Design Modification
FELs: PM 0.09 g/kW-hr

Pursuant to Section 111 and Section 213 of the Clean Air Act (42 U.S.C. sections 7411 and 7547) and 40 CFR Parts 60 and 1039, and subject to the terms and conditions prescribed in those provisions, this certificate of conformity is hereby issued with respect to the test engines which have been found to conform to applicable requirements and which represent the following engines, by engine family, more fully described in the documentation required by 40 CFR Parts 60 and 1039 and produced in the stated model year.

This certificate of conformity covers only those new compression-ignition engines which conform in all material respects to the design specifications that applied to those engines described in the documentation required by 40 CFR Parts 60 and 1039 and which are produced during the model year stated on this certificate of the said manufacturer, as defined in 40 CFR Parts 60 and 1039.

It is a term of this certificate that the manufacturer shall consent to all inspections described in 40 CFR 1068 and authorized in a warrant or court order. Failure to comply with the requirements of such a warrant or court order may lead to revocation or suspension of this certificate for reasons specified in 40 CFR Parts 60 and 1039. It is also a term of this certificate that this certificate may be revoked or suspended or rendered void *ab initio* for other reasons specified in 40 CFR Parts 60 and 1039.

This certificate does not cover engines sold, offered for sale, or introduced, or delivered for introduction, into commerce in the U.S. prior to the effective date of the certificate.

This certificate of conformity is conditional upon compliance of said manufacturer with the averaging, banking and trading provisions of 40 CFR Part 1039, Subpart H. Failure to comply with these provisions may render this certificate void *ab initio*.

F. CPCN EXEMPTION APPROVAL LETTER

FREDERICK H. HOOVER, JR.
CHAIR

KUMAR P. BARVE
BONNIE A. SUCHMAN
ODOGWU OBI LINTON
RYAN C. MCLEAN



PUBLIC SERVICE COMMISSION

#1, 10/29/25 AM; ML#s 322161 and 322741, IR-8913

October 29, 2025

Justin Raducha
Justin.Raducha@va.gov

Dear Mr. Raducha:

The Commission has reviewed the request for approval to construct a generating station at the Perry Point VA Medical Center filed on September 5, 2025 by U.S. Department of Veterans Affairs. Additional information was filed on September 26, 2025.

After considering this matter at the October 29, 2025 Administrative Meeting, the Commission approved the application.

By Direction of the Commission,

/s/ Amanda Best

Amanda Best
Deputy Executive Secretary

AB/st

G. EVIDENCE OF WORKMAN'S COMPENSATION INSURANCE



CERTIFICATE OF LIABILITY INSURANCE

DATE (MM/DD/YYYY)

8/20/2025

THIS CERTIFICATE IS ISSUED AS A MATTER OF INFORMATION ONLY AND CONFERS NO RIGHTS UPON THE CERTIFICATE HOLDER. THIS CERTIFICATE DOES NOT AFFIRMATIVELY OR NEGATIVELY AMEND, EXTEND OR ALTER THE COVERAGE AFFORDED BY THE POLICIES BELOW. THIS CERTIFICATE OF INSURANCE DOES NOT CONSTITUTE A CONTRACT BETWEEN THE ISSUING INSURER(S), AUTHORIZED REPRESENTATIVE OR PRODUCER, AND THE CERTIFICATE HOLDER.

IMPORTANT: If the certificate holder is an ADDITIONAL INSURED, the policy(ies) must have ADDITIONAL INSURED provisions or be endorsed. If SUBROGATION IS WAIVED, subject to the terms and conditions of the policy, certain policies may require an endorsement. A statement on this certificate does not confer rights to the certificate holder in lieu of such endorsement(s).

PRODUCER Risk Strategies 230 Schilling Circle, Suite 338 Hunt Valley MD 21031	CONTACT NAME: Lacey Alvis PHONE (A/C, No, Ext): 410-561-3593 E-MAIL ADDRESS: LAlvis@risk-strategies.com		FAX (A/C, No): 410-561-3727		
	INSURER(S) AFFORDING COVERAGE				
INSURED MEM Contracting, Inc. 819 S. Philadelphia Blvd Suite C Aberdeen MD 21001	MEMCO-1	INSURER A :	The Phoenix Insurance Co.	NAIC #	25623
		INSURER B :	Charter Oak Fire Insurance Com		25615
		INSURER C :	Travelers Property Casualty		25674
		INSURER D :	Travelers Indemnity Company		25658
		INSURER E :			
		INSURER F :			

COVERAGES

CERTIFICATE NUMBER: 1261283969

REVISION NUMBER:

THIS IS TO CERTIFY THAT THE POLICIES OF INSURANCE LISTED BELOW HAVE BEEN ISSUED TO THE INSURED NAMED ABOVE FOR THE POLICY PERIOD INDICATED. NOTWITHSTANDING ANY REQUIREMENT, TERM OR CONDITION OF ANY CONTRACT OR OTHER DOCUMENT WITH RESPECT TO WHICH THIS CERTIFICATE MAY BE ISSUED OR MAY PERTAIN, THE INSURANCE AFFORDED BY THE POLICIES DESCRIBED HEREIN IS SUBJECT TO ALL THE TERMS, EXCLUSIONS AND CONDITIONS OF SUCH POLICIES. LIMITS SHOWN MAY HAVE BEEN REDUCED BY PAID CLAIMS.

INSR LTR	TYPE OF INSURANCE	ADDL INSD	SUBR WVD	POLICY NUMBER	POLICY EFF (MM/DD/YYYY)	POLICY EXP (MM/DD/YYYY)	LIMITS	
A	<input checked="" type="checkbox"/> COMMERCIAL GENERAL LIABILITY <input type="checkbox"/> CLAIMS-MADE <input checked="" type="checkbox"/> OCCUR GEN'L AGGREGATE LIMIT APPLIES PER: <input type="checkbox"/> POLICY <input checked="" type="checkbox"/> PRO-JECT <input type="checkbox"/> LOC <input type="checkbox"/> OTHER:			DT-CO-0X39401A-PHX-25	9/1/2025	9/1/2026	EACH OCCURRENCE	\$ 1,000,000
							DAMAGE TO RENTED PREMISES (Ea occurrence)	\$ 1,000,000
							MED EXP (Any one person)	\$ 10,000
							PERSONAL & ADV INJURY	\$ 1,000,000
							GENERAL AGGREGATE	\$ 2,000,000
							PRODUCTS - COMP/OP AGG	\$ 2,000,000
								\$
D	<input checked="" type="checkbox"/> AUTOMOBILE LIABILITY <input checked="" type="checkbox"/> ANY AUTO <input type="checkbox"/> OWNED AUTOS ONLY <input type="checkbox"/> SCHEDULED AUTOS <input checked="" type="checkbox"/> HIRED AUTOS ONLY <input checked="" type="checkbox"/> NON-OWNED AUTOS ONLY			BA-0X393792-25-26-G	9/1/2025	9/1/2026	COMBINED SINGLE LIMIT (Ea accident)	\$ 1,000,000
							BODILY INJURY (Per person)	\$
							BODILY INJURY (Per accident)	\$
							PROPERTY DAMAGE (Per accident)	\$
								\$
C	<input checked="" type="checkbox"/> UMBRELLA LIAB <input checked="" type="checkbox"/> OCCUR <input type="checkbox"/> EXCESS LIAB <input type="checkbox"/> CLAIMS-MADE <input type="checkbox"/> DED <input checked="" type="checkbox"/> RETENTION \$ 0			CUP-0X39436A-25-26	9/1/2025	9/1/2026	EACH OCCURRENCE	\$ 5,000,000
							AGGREGATE	\$ 5,000,000
								\$
B	WORKERS COMPENSATION AND EMPLOYERS' LIABILITY ANY PROPRIETOR/PARTNER/EXECUTIVE OFFICER/MEMBER EXCLUDED? (Mandatory in NH) If yes, describe under DESCRIPTION OF OPERATIONS below	Y/N	N/A	UB-0X393780-25-26-G	9/1/2025	9/1/2026	<input checked="" type="checkbox"/> PER STATUTE <input type="checkbox"/> OTHER	
							E.L. EACH ACCIDENT	\$ 1,000,000
							E.L. DISEASE - EA EMPLOYEE	\$ 1,000,000
							E.L. DISEASE - POLICY LIMIT	\$ 1,000,000

DESCRIPTION OF OPERATIONS / LOCATIONS / VEHICLES (ACORD 101, Additional Remarks Schedule, may be attached if more space is required)
 Re: VA 36C24518D0011 MATOC contract

CERTIFICATE HOLDER**CANCELLATION**

Department of Veterans Affairs
 VA Maryland Health Care System
 P.O. Box 1000, Bldg. 101B, Room 10
 Perry Point MD 21902

SHOULD ANY OF THE ABOVE DESCRIBED POLICIES BE CANCELLED BEFORE THE EXPIRATION DATE THEREOF, NOTICE WILL BE DELIVERED IN ACCORDANCE WITH THE POLICY PROVISIONS.

AUTHORIZED REPRESENTATIVE

© 1988-2015 ACORD CORPORATION. All rights reserved.