



DAM SAFETY
POLICY MEMORANDUM #2

TO: Dam Owners, Operators, and Engineers

FROM: Sediment, Stormwater, and Dam Safety Program
Water and Science Administration

DATE: June 11, 2019 (Updated October 9, 2019, February 21, 2020)

SUBJECT: Roadway/Railroad Embankment with Culvert Crossing

Policy Statement

It is the policy of the Maryland Department of the Environment (the Department) that linear embankments constructed as transportation ways should be designed to avoid impounding water excessively, for any purpose, through the use of adequately sized culverts, bridges or similar elements. Where linear embankments impound excessive depths of water, they will be classified as dams and must be designed, constructed, and operated as such.

Conditions Where this Policy Applies

The criteria below are used to determine whether a roadway or railroad embankment is functioning as a dam. These criteria apply irrespective of embankment width and may be applied to hiker/biker paths, golf cart paths, and narrow access roads. The criteria provide a measure for adequately sizing the culvert crossing to limit the impounded water and eliminate the embankment from being considered a dam. Application for a dam safety permit is required for embankments higher than 35 feet. For roadways, the embankment height is measured from the lowest point of excavation or fill on the upstream slope of the embankment to the incipient point of overtopping. For railroads, the embankment height is measured from the lowest point of excavation or fill on the upstream slope of the embankment to the subballast at the incipient point of overtopping.

1. Headwater and tailwater conditions are based on the 100-year, 24 hour storm event. Headwater depth (HW_{depth}) is measured from the upstream toe of fill to the upstream hydraulic grade line (HGL) or 100-year water surface elevation (HW_{elev}) assuming there is no velocity head. Tailwater depth (TW_{depth}) is measured from the downstream toe of fill to the downstream HGL (TW_{elev}). In the equations below, “HW-TW” refers to the differential between headwater and tailwater elevations. When the 100-year TW_{elev} is lower than the

elevation of the pipe invert at the upstream end, the HW_{depth} shall be substituted for “HW-TW”. D is the diameter of the culvert. For box culverts, twin culverts, and elliptical pipes, consider D to be the height of the opening. Refer to Figures 1 and 2 for illustration of the definitions provided above.

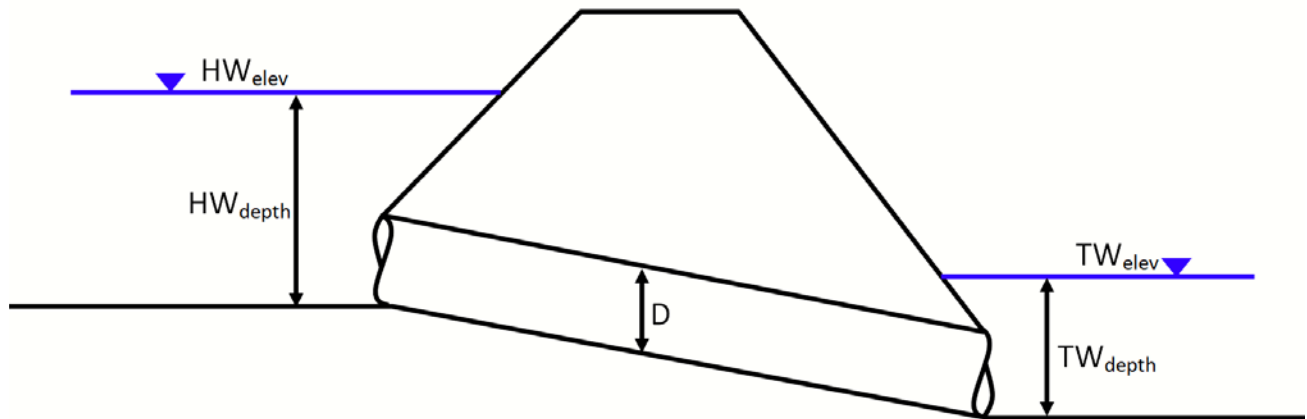

Figure 1: Illustration of condition where TW_{elev} is higher than upstream invert elevation;
use $HW-TW = HW_{elev} - TW_{elev}$

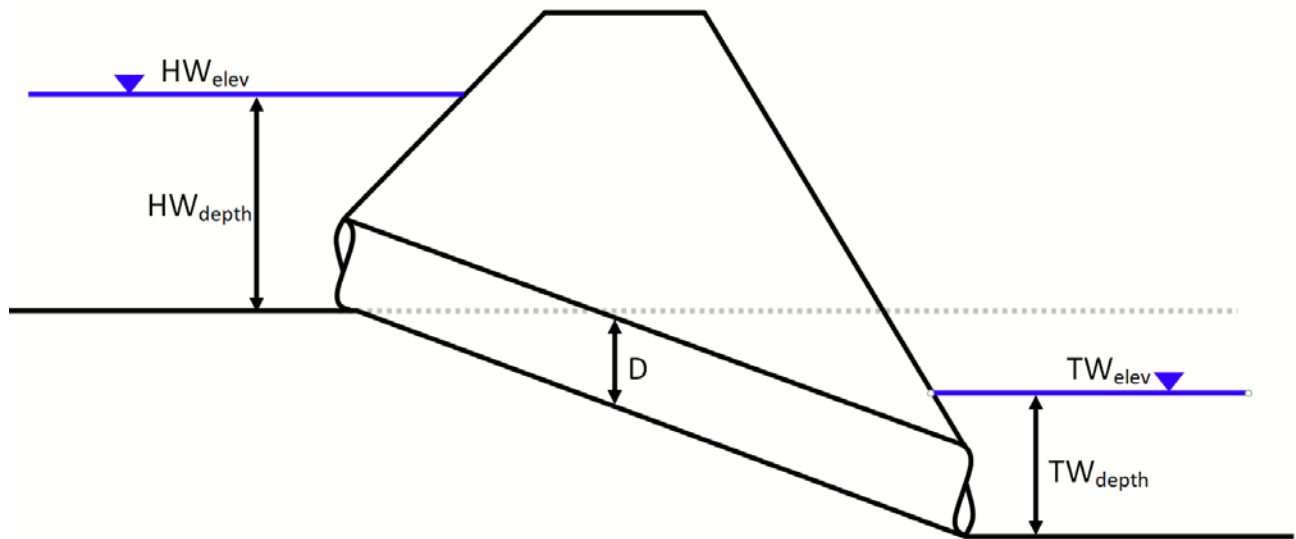

Figure 2: Illustration of condition where TW_{elev} is lower than upstream invert elevation;
use $HW-TW = HW_{depth}$

2. A conduit penetrating a roadway or railroad embankment is considered a dam when any one of these three conditions exists:
 - a. $HW-TW > 10$ feet and $HW_{depth}/D > 2$; or
 - b. Permanent pool > 3 feet; or
 - c. The culvert includes a structure to control water surface elevations (e.g., riser, weir).
3. Conversely, a conduit penetrating a roadway or railroad embankment is considered a culvert when all four of these conditions are met:
 - a. $HW-TW \leq 10$ feet or $HW_{depth}/D \leq 2$;
 - b. Permanent pool ≤ 3 feet;
 - c. There is no structure to control water surface elevations; and
 - d. The embankment height is ≤ 35 feet
4. Crossings consisting of multiple pipes at significantly different invert elevations (more than one (1) foot difference in inverts or as stipulated for animal passage) or box culverts that are taller than they are wide are disqualified from using the criteria above when the capacity of the pipe(s) has been reduced such that it manages stormwater discharges. In these situations, the crossing will be considered to act as a dam. A dam breach analysis will be required, and the embankment will have to be designed in accordance with Dam Safety regulations and policies. The Department encourages the designer to re-configure the crossing and size the culvert(s) to not store water and to address stormwater management requirements in a separate BMP.
5. The above criteria for evaluating whether the roadway/railroad embankment is acting as a dam shall be applied to crossings that are interrupted by a structure (manhole or inlet) or consist of more than one section of pipe. If the downstream pipe section is smaller than the upstream pipe, D shall correspond to diameter of the smaller pipe.
6. Note that based on the roadway/railroad geometry alone, it may be possible to eliminate smaller embankments from consideration without calculating the headwater and tailwater. If the crest of roadway/railroad embankment is less than or equal to ten (10) feet above the downstream toe, then the crossing will be considered a culvert, assuming there is no riser (or similar water control structure) or no permanent pool deeper than three (3) feet.

7. Embankments taller than 35 feet shall be submitted to the Dam Safety Division for review through the Joint Permit Applicant process. A dam breach analysis shall be provided unless the embankment meets the all following criteria:
- $HW-TW \leq 10$ feet or $HW_{depth}/D \leq 1.5$;
 - Permanent pool ≤ 3 feet;
 - There is no structure to control water surface elevations; and
 - Smaller of brim-full storage volume or probable maximum flood (PMF) storage, is less than indicated in the following table.

Embankment Width*(ft.)	Max. Storage Volume (acre-ft.)
8 to 25 feet	5
25.01 to 50	20
50.01 to 75	60
75.01 to 100	100
100.01 and greater	Less than 150

*When brim-full storage volume controls, embankment width shall be measured at one (1) foot below the crest of the dam. When the PMF water surface elevation is less than the brim-full elevation, embankment width shall be measured at the PMF water surface elevation.

Embankments that meet criteria (a), (b), (c), and (d) will be considered low hazard and may, at the Department's discretion, be considered a culvert and will not require a Dam Safety Permit.

8. The HW and TW shall be calculated using NRCS methodology, except where the embankment is less than 35 feet in height and the conduit in question has a drainage area of five (5) acres or less, in which case the Rational Method is acceptable. Land use shall be based on ultimate development.

Additional Information

Questions about this policy or other items relating to ponds and dams can be directed to the Chief of the Dam Safety Division at 410-537-3538.